

Economic and Social Commission for Asia and the Pacific

---

---

# Assessment of the Environmental Impact of Port Development

---

---

**A Guidebook for EIA of Port Development**



**UNITED NATIONS**

**New York, 1992**

ST/ESCAP/1234

The designations employed and the presentation of the material in this publication do not imply the expression of any opinion whatsoever on the part of the Secretariat of the United Nations concerning the legal status of any country, territory, city or area, or of its authorities, or concerning the delimitation of its frontiers or boundaries.

This publication has been issued without formal editing.

# CONTENTS

<u>Chapter</u>		<u>Page</u>
	INTRODUCTION	1
1	REQUIREMENTS FOR EIA	2
2	ENVIRONMENTAL IMPACTS OF PORT DEVELOPMENT	6
2.1	IMPACTS OF LOCATION OF PORT .....	9
2.2	IMPACTS OF CONSTRUCTION .....	11
2.3	IMPACTS OF SHIP TRAFFIC AND DISCHARGES ..	14
2.4	IMPACTS OF CARGO OPERATIONS AND WATERFRONT INDUSTRY .....	15
2.5	CHECK LISTS OF POTENTIAL ADVERSE EFFECTS	18
3	ENVIRONMENTAL INDICATORS AND CRITERIA	19
3.1	WATER QUALITY AT SEA .	19
3.2	BOTTOM CONTAMINATION	19
3.3	AIR QUALITY .....	20
3.4	NOISE .....	20
3.5	ODOUR .....	20
4	METHODS FOR SURVEY AND IMPACT PREDICTION	28
4.1	WATER POLLUTION .....	28
4.1.1	Survey of water pollution .....	28
4.1.2	Prediction of water pollution ..	29
4.1.3	Dispersal of thermal discharge	31
4.1.4	Dispersal of turbid water .....	32
4.1.5	Eutrophication .....	32
4.2	COASTAL HYDROLOGY .....	33
4.2.1	Survey of tides, currents and waves .....	33
4.2.2	Prediction of changes in coastal hydrology	34
4.3	MARINE AND COASTAL ECOLOGY	35
4.4	AIR QUALITY .....	35
4.4.1	Survey on air pollution .....	36
4.4.2	Prediction of impacts on air quality	36
4.5	NOISE .....	37
4.5.1	Survey of noise .....	37
4.5.2	Prediction of noise transmission	38
4.6	ODOUR .....	38
4.7	VISUAL POLLUTION	38
5	METHODS FOR POLLUTION-LESS DREDGING AND RECLAMATION	39
5.1	DREDGING OF SLUDGE	39
5.2	LAND RECLAMATION ..	41

## REFERENCES

42

## APPENDICES

1	WORLD BANK CHECK LIST OF ENVIRONMENTAL IMPACTS FOR PORT AND HARBOR PROJECTS	43
2	ADB CHECK LIST OF ENVIRONMENTAL PARAMETERS FOR PORTS AND HARBORS PROJECTS . . . . .	50
3	IAPH CHECK LIST OF ENVIRONMENTAL IMPACTS OF PORTS AND COASTAL AREA DEVELOPMENTS . . . . .	53
4	LONDON DUMPING CONVENTION	56
5	(1) CRITERIA FOR THE REMOVAL OF MERCURY CONTAMINATED SEDIMENTS . . . . .	61
	(2) ESTIMATION OF THE AMOUNT OF POLLUTANTS	61
6	(1) NITTA'S EXPERIMENTAL EQUATION	62
	(2) JOSEPH-SENDNER'S EQUATION	62
	(3) BOX MIXING MODEL . . .	63
7	DISPERSAL OF THERMAL DISCHARGE	66
8	DISPERSAL OF TURBID WATER	67
9	TYPICAL PATTERNS OF BEACH EROSION AND ACCRETION	69
10	LEVELS OF EUTROPHICATION	70
11	GAS EMISSION AND DISPERSION	71
12	(1) NOISE TRANSMISSION	72
	(2) ANGLES OF VIEW	72
13	TYPES OF SETTLING POND	73

## INTRODUCTION

Since 1972 when the United Nations Conference on Human Environment addressed the impact of environment on our life, the international has realized that environmental problems should be of common concern community. Nevertheless, rapid economic growth and the development of supporting infrastructure has caused a number of problems, including those associated with port and harbour construction and operation.

Economic growth in the Asia and Pacific region has, during the past decade, exceeded that of any other region in the world. Much of this growth resulted in the expansion of international trade. Consequently, seaborne cargo throughput has increased rapidly, in the major ports of the region served by the Economic and Social Commission for Asia and the Pacific (ESCAP), to the point where port capacities need to be expanded. At the same time, larger and more specialized vessels have been introduced to take advantage of economies of scale and to minimize costs. As a result, deeper channels, new or improved wharves and modern cargo handling facilities are required.

While expansion of port facilities can make a significant contribution to economic development and the growth of maritime transport, it may also create adverse impacts on the surrounding environment. Port development and operation should, therefore, be planned with careful consideration of their environmental impacts. To contribute to the global initiatives to sustain the environment ESCAP launched this study on the importance of environmentally sound port development and the urgency of its achievement.

Checklists for port development and environment protection have already been released by the World Bank, the Asian Development Bank and the International Association of Ports and Harbours, these are listed in appendices. Guidelines for Environmental Impact Assessment (EIA) have also been developed in several countries of the region. To achieve environmentally sound and sustainable port development and management, efforts should be placed on familiarizing EIA and recalling the importance of allocating financial and human resources to environmental protection activities in developing and operating ports.

This guidebook is intended to provide port planners with basic practical information on EIA of port development. It therefore includes a checklist of potential adverse effects of port development and operation, mitigating actions, methods of prediction, information on environmental indicators and regulations on their permissible levels. However, in many cases the studying of more detailed literature is advised.

The ESCAP secretariat wishes to thank the Government of Japan which kindly funded this study and furnished information. Appreciation is also expressed to the Overseas Coastal Area Development Institute of Japan whose effort made it possible to collect relevant data compiled in this guidebook.

# 1 REQUIREMENTS FOR EIA

Port development may create a wide range of impacts on the environment by dredging, construction work, landfills, discharges from ships and waterfront industries, cargo operations, and other port related activities. The potential adverse effects of port development encompass water pollution, contamination of bottom sediments, loss of bottom habitat, damage to marine ecology and fisheries, beach erosion, current pattern changes, waste disposal, oil leakage and spillage, hazardous material emissions, air pollution, noise, vibration, visual pollution, and other unhealthy socio-cultural impacts.

To minimize these adverse effects that may be created by port development projects the techniques of Environmental Impact Assessment (EIA) become indispensable. Legislation and administrative regulations on EIA are being adopted in many countries partly due to pressure from funding agencies which request EIA as part of the appraisal of development project and partly due to the increasing environmental awareness in the regional member countries.

EIA procedures are designed to identify environmental problems which may be caused by a development project and determine the magnitude of change in the environment. Through this process design, location and operational changes can be introduced to minimize the adverse impacts of the development. EIA usually has preliminary and detailed phases. The first phase is called an Initial Environmental Examination (IEE) and the second is Environmental Impact Studies (EIS) or simply detailed EIA.

The IEE is a study on potential impacts which a proposed project might have on the environment. The IEE contains a brief statement of key environmental issues, based on readily available information, and is used in the early (pre-feasibility) phase of project planning. The IEE also suggests whether in-depth studies are needed. An EIA is a more detailed study of the probable significant effects both beneficial and adverse which a proposed project will have on the environment.

A typical procedure for carrying out EIA is as follows:

- (a) Check legislation and regulations on environmental requirements (If required, prepare an IEE based on certain terms of reference);
- (b) Review the IEE submitted and determine whether an EIA is required;
- (c) Review the EIA report to check its completeness, accuracy, compliance with requirements, appropriateness and adequacy of proposed environmental protection methods;
- (d) Notify the public and request their comments;
- (e) Prepare countermeasures to offset or mitigate adverse effects anticipated;
- (f) Adopt or reject the proposed project; and
- (g) Monitor environmental changes during construction and subsequent operations.

EIA methodologies were originally designed to meet the demand of environmental lobbies but has now become an essential, integrated part of planning due to the recognition that environmental issues should be embedded in the decision-making process. Training for EIA drafters and resource managers is undertaken in several countries of the region and general guidelines for EIA are shown in table 1.2. These general guidelines are applied to all

kinds of development projects, however, the potential adverse effects of port development are so diverse that specific environmental guidelines for this sector are required.

While EIA studies are becoming more common in developing countries, some difficulties have been encountered in implementing EIA procedures and in the appropriate shaping of projects. These problems include:

- (a) Insufficient awareness of decision makers regarding environmental problems;
- (b) Legal and institutional constraints owing to inadequate arrangements for EIA implementation;
- (c) Shortage of expertise and experience, particularly lack of skilled manpower;
- (d) Difficulty in accessing the latest technical information on EIA;
- (e) Lack of appropriate environmental data and information required for EIA; and
- (f) Inadequate awareness of the potential impacts of development project on the environment within the general public.

It must be accepted that development of a port and its subsequent operation must have some impact on the environment. The purpose of the EIA is to quantify the impact and ensure that changes to the environment fall within acceptable pre-defined limits. In an ideal situation, the whole EIA process will be undertaken in parallel with the conceptualization, design and operation of port facilities. While the EIA process can be complex and sometimes expensive the early identification of adverse environmental impacts can provide the opportunity to take early corrective actions. This action could be as drastic as relocating port facilities and undertaking a significant redesign to accommodate different soil/water conditions or as simple as planting additional trees. In either case the purpose is to accommodate the environmental needs of the country and community so that the port can fulfil its economic function without adversely effecting its environment.

In the following pages a structural approach has been taken to reviewing the potential impact of port development on the environment, selected legislation and conventions, acceptable limits of change created by the development. The report also indicates how the environmental impact of port development can be mitigated.

**TABLE 1.1 Status of EIA requirements for port and harbour development projects**

Country/Area	Status of EIA requirements			
	A	B	C	D
Australia				
Bangladesh				
Brunei Darussalam				
Fiji				
Hong Kong				
India				
Indonesia				
Japan				
Malaysia				
New Caledonia				
New Zealand				
Pakistan				
Papua New Guinea				
Philippines				
Republic of Korea				
Singapore				
Solomon Islands				
Tahiti				
Thailand				
Tonga				
Viet Nam				

Type of EIA legislation

A: Specific legislation on EIA

B: Administrative requirements from a government agency for particular projects.

C: No local requirements for EIA but through the request of international funding agencies such as the World Bank or Asian Development Bank.

D: No particular requirement for EIA

Source: Summary of "Questionnaire on Environmental Impact Assessment in your port(s), April 1991" TACD, ESCAP

**TABLE 1.2 EIA guidelines in the countries of the ESCAP region**

<b>Country</b>	<b>Guidelines</b>
China:	Management Guidelines on Environmental Protection of Construction Projects of The People's Republic of China (1986)
India:	Guidelines and Questionnaire for Environmental Impact Assessment of Shipping and Harbour Projects, Ministry of Environment & Forests, (1981)
Indonesia:	Government Regulation No.29, 1986 regarding the Analysis of Impacts upon the Environment
Malaysia:	A Handbook of Environmental Impact Assessment Guidelines 1987, Department of Environment
Pakistan:	Environmental Impact Assessment Guidelines 1986, Ministry of Housing & Works, Environment & Urban Division in cooperation with Asian Development Bank
Philippines:	Environmental Impact Assessment Handbook 1983, Ministry of Human Settlements, National Environmental Protection Council
Republic of Korea:	Guidelines of EIS (EA Notice No.87-13)
Sri Lanka:	Hand-book on Environmental Impact Assessment 1987, Central Environmental Authority
Thailand:	General Guidelines for Preparation of Environment Impact Statement Guidelines for Preparation of Initial Environmental Examination

Source: Study report on Environmental Impact of Port Development in Countries of the ESCAP Region, K. Dohi, April 1992

## 2 ENVIRONMENTAL IMPACTS OF PORT DEVELOPMENT

Checklists of adverse effects of port development for EIA have been compiled by several organizations including the World Bank, the Asian Development Bank and the International Association of Ports and Harbors. Based on a review of these checklists, the relationship between factors in port development and their impacts on the environment has been outlined in table 2.1.

Major sources of these adverse effects can be categorized into three types: (a) location of port; (b) construction; and (c) port operation, including ship traffic and discharges, cargo handling and storage, and land transport. **Location of port** connotes the existence of structures or landfills, and the position of the development site. **Construction** implies construction activities in the sea and on land, dredging, disposal of dredged materials, and transport of construction materials. **Port operation** includes ship-related factors such as vessel traffic, ship discharges and emissions, spills and leakage from ships; and cargo-related factors such as cargo handling and storage, handling equipment, hazardous materials, waterfront industry discharges, and land transport to and from the port.

Environmental facets to be considered in relation to port development are categorized into nine groups: (a) water quality; (b) coastal hydrology; (c) bottom contamination; (d) marine and coastal ecology; (e) air quality; (f) noise and vibration; (g) waste management; (h) visual quality; and (i) socio-cultural impacts.

Water quality includes five elements: (a) general features such as temperature, salinity, pH, colour, transparency, oil and grease, and organic material concentration measured by total organic carbon (TOC), chemical oxygen demand (COD) or biochemical oxygen demand (BOD); (b) turbidity measured by suspended solids (SS); (c) eutrophication-related factors measured by dissolved oxygen (DO), nitrogen (N) and phosphorus (P); (d) harmful or toxic substances including heavy metals such as mercury, cadmium, lead, and pesticides; and (e) sanitation-related factors determined by measuring the amount of coliform bacteria.

Coastal hydrology cited here includes factors concerning currents, tidal flow, littoral drifts, beach erosion, water drainage, sediment deposition, groundwater flow, and other physical phenomena in the shore zone.

Bottom contamination encompasses many kinds of contamination of bottom sediments by toxic or harmful substances, oils, oily mixtures and other hazardous materials. Contamination of bottom sediments are often measured by the size of sediment particles, pH, colour, smell, oil and grease, organic materials, and concentration of organic nitrogen, phosphorus, sulphide, and toxic substances such as heavy metals and pesticides including toxic components of antifouling paints.

Marine and coastal ecology includes aquatic fauna and flora composed of a large number of species of bacteria, phytoplankton, zooplankton, benthonic organisms, coral, seaweed, shellfish, fish and other aquatic biota, terrestrial flora such as mangroves and wetlands. Loss of bottom habitat and fishery resources are also significant problems included in this category.

Air quality consists of two main elements: (a) soot and dust, measured by suspended particulate matter (SPM), which originate from dry bulk cargo handling and storage, construction work on land, and road traffic; and (b) concentration of sulfur dioxide (SO<sub>2</sub>), nitrogen dioxide (NO<sub>2</sub>), carbon monoxide (CO), and hydrocarbons (HC) emitted from ships,

vehicles and various equipment used for port activities. Harmful substances and odour are also elements to be considered in this category.

Noise and vibration generated by road traffic, cargo operations, ship traffic and other port activities also cause nuisances to local people.

Waste management relates to all kinds of wastes, both liquid and solid, likely to be disposed of in the port area. These wastes include dredged materials, garbage and oily mixtures discharged from ships, wastes from cargo operations, and all types of discharges from municipal and waterfront industry activities.

Visual quality refers to the aesthetic value of the landscape, the view of port facilities, the nuisance of bright lights used for night operations in a port, and other visual problems.

Socio-cultural impacts includes all kinds of influence on the local community and people's life style such as relocation of villages, industrialization, population growth nearby, and the formation of slums.

The following section reviews the potential impacts of port activities on each facet of the environment and possible measures against potential adverse effects. Relations between impact sources and various part of the environment are summarized in table 2.1.

**TABLE 2.1 Major impacts of port development project on the environment**

Facet of the Environment	Location of port (A)	Construction and dredging (B)	Port operation	
			Ship traffic and discharges (C)	Cargo operations and waterfront industry (D)
Water quality (1)	A1	B1	C1	D1
Coastal hydrology (2)	A2	B2	-	-
Bottom contamination (3)	A3	B3	-	D3
Marine/coastal ecology (4)	A4	B4	C4	D4
Air quality (5)	-	B5	C5	D5
Noise and vibration (6)	-	B6	-	D6
Waste management (7)	-	B7	C7	D7
Visual quality (8)	A8	-	-	D8
Socio-cultural impact (9)	A9	-	C9	D9

## **2.1 IMPACTS OF LOCATION OF PORT**

### **2.1.1 Potential impacts on water quality (A1 of table 2.1)**

Breakwaters and landfills may change current patterns and cause stagnation of water behind the structures. If municipal or industrial effluent flows into a port, stagnant port water may deteriorate through a dramatic increase of phytoplankton and a decrease of dissolved oxygen, resulting from eutrophication of water, caused by effluents containing nutrient salts (chemical compounds including N and P). Anaerobic water leads to the generation of hydrogen sulphide (H<sub>2</sub>S) and can be identified by its odour. It has serious effects on organisms. Municipal sewage also brings coliform bacteria into the port and may cause unacceptable contamination of the harbour.

#### **Measures against adverse effects**

Careful site selection and port design should be carried out, focusing on the possibility of water stagnation. If the basic pollution level is critically high, a sewage treatment system should be planned as part of the environment management of the area. Regulations on discharges of effluents into water and provision of sanitary treatment facilities are indispensable for reducing pollutants from hinterlands. In a polluted bay or port, it could be effective to dredge or cover contaminated bottom sediment capping to reduce the flux of pollutants from the sediment to the water.

### **2.1.2 Potential impacts on coastal hydrology (A2 of table 2.1)**

The location of a port may cause changes in current patterns and littoral drifts due to alteration of wave refraction, diffraction and reflection. The change of littoral drift may lead to erosion or accretion in shore zones. Altered currents or reflected waves may endanger small ships maneuvering near structures. The creation of a port may cause changes in river flow and waterfront drainage.

#### **Measures against adverse effects**

Careful site selection and port design could minimize changes in current patterns and other coastal hydrology. Model experiments or computer simulations of these changes are useful in developing an appropriate design. Typical measures against beach erosion are construction of sea walls, jetties, offshore breakwaters, and periodical beach nourishment.

### **2.1.3 Potential impacts on bottom contamination (A3 of table 2.1)**

The location of a port may accelerate sediment deposition in stagnant water behind structures and cause contamination of the sea bottom. Sediment deposition covers bottom biota and physical habitat. Pile structures shade the bottom and affect habitat. Eutrophication of water induces sedimentation of dead plankton and changes chemical characteristics of bottom sediments, resulting in an increase of organic matter, hydrogen sulphide, and mobilization of harmful substances.

#### **Measures against adverse effects**

Removal of contaminated sediments, capping, as well as other measures mentioned in subsection 2.1.1 could be effective measures against adverse effects on water quality.

#### **2.1.4 Potential impacts on marine/coastal ecology (A4 of table 2.1)**

The location of a port affects aquatic fauna and flora through changes of water quality, coastal hydrology and bottom contamination. Land reclamation from the sea destroys bottom habitat and displaces fishery resources. Terrestrial fauna and flora may also be altered by the location of a port.

Diminution of bottom biota is usually linked to a reduction of fishery resources, and occasionally to an increase of undesirable species. Deterioration of water quality usually gives rise to changes in aquatic biota: a decrease in the number of species; and an increase in the quantity of one or two specific species. Further deterioration may lead to the destruction of all kinds of aquatic biota.

Diminution of plants in a shore zone within enclosed water may degrade its aeration capability and worsen water pollution. Mangroves in wetlands play an important role in providing habitat for terrestrial and aquatic biota and indirectly recovering water quality.

##### **Measures against adverse effects**

Adverse effects on marine and coastal ecology usually result from: deterioration of water and air quality; current pattern changes; bottom contamination; physical loss of water area; and changes in natural land habitat. Measures mentioned in subsections 2.1.1 and 2.1.3 are effective for mitigating changes in aquatic and terrestrial habitat. Careful survey of the ecological characteristics of a project area is indispensable if the welfare of endangered and fragile species is to be considered and disruption of their spawning seasons and areas and migration is to be minimized. Planting of green plants around a port may be an effective means to mitigate adverse effects on terrestrial habitat.

#### **2.1.5 Potential impacts on visual quality (A8 of table 2.1)**

The visual quality of a project area is affected by the creation of a port, port facilities, lighting, and other optical disturbances. The landscape may be changed into an artificial scene of industrialization. Some port facilities may give an unpleasant impression to people.

##### **Measures against adverse effects**

The design of port should cause it to blend with its surroundings. Special attention to the colors of port facilities and landmarks helps improve port scenery. A green belt zone around a port may block an unpleasant view of the port and be a more pleasant sight.

#### **2.1.6 Socio-cultural impacts (A9 of table 2.1)**

Building or expanding a port often requires relocation of the local community, sometimes causing ethnic, cultural, tribal, or religious conflicts with local people. Industrialization and modernization may change the cultural traditions of the local community.

##### **Measures against adverse effects**

An appropriate resettlement plan could minimize the disturbance to the local community and ensure smooth transition to industrialization. Survey of archaeological heritage sites should be undertaken well in advance and a preservation plan included in any port development plan. During the evaluation stage of a development project, following information should be provided:

- (a) Distribution of population around the project area:  
Initial population distribution, age composition, households, slums, social solidarity, public peace and order, infrastructure
- (b) Race composition:  
Majority and minority groups, cultural gaps, basic resources for life, racial conflicts
- (c) Removal and resettlement of local people:  
Removal population, conservation of community, condition of resettlement, opinions on removal and resettlement
- (d) Cultural heritage:  
Location of heritage, importance of heritage, legislation on preservation, possibility of removal

## **2.2 IMPACTS OF CONSTRUCTION**

### **2.2.1 Potential impacts on water quality (B1 of table 2.1)**

Pile driving, deposition of rubble, dredging, sand compaction and other construction work in water cause resuspension of sediments and turbid water. Resuspension of sediments in water leads to an increase in the level of suspended solids (SS) and in the concentration of organic matter, possibly to toxic or harmful levels. It also reduces sunlight penetration.

Work vessels are a possible cause of oil spills, garbage discharge, and leakage of other substances into water. Diffusion from concrete work in water and overflows from landfills may be possible sources of water pollution.

#### **Measures against adverse effects**

The adverse effects of construction work could be minimized by appropriate selection of equipment in pile driving or dredging, proper use of silt curtains, careful planning of settling ponds and overflow weirs for landfills, and suitable transport of construction materials and dredged material. Proper disposal of dredged material plays a critical part in preserving the environment. Deposition in landfills may offset problems being caused by dumping at sea.

### **2.2.2 Potential impacts on coastal hydrology (B2 of table 2.1)**

The potential impacts of construction on coastal hydrology are nearly the same as the potential impacts of the location of a port which are identified in subsection 2.1.2. Dredging may cause changes in current patterns and flows as well as salt wedge intrusion into a river mouth or littoral drifts in the shore zone. Changes in littoral drifts lead to beach erosion or accretion. Disposal of dredged material on land may possibly cause leakage of harmful substances into ground water or changes in waterfront drainage.

### **Measures against adverse effects**

The impact of dredging on current flow is usually not serious and can be assessed by current flow simulation. Beach erosion could be avoided by carefully planning the steepness of the dredging slope and the deviation from the shore line.

## **2.2.3 Potential impacts on bottom contamination (B3 of table 2.1)**

Construction work and dredging disturb bottom sediments and induce resuspension, dispersal and settlement of such sediments. Dumping of dredged material directly alters bottom configuration and biota and may disperse toxic or harmful chemicals around the disposal site. Dredging removes bottom habitat and may lead to a loss of fishery resources.

### **Measures against adverse effects**

A survey of contamination of bottom sediments should be undertaken before dredging. In case substances or materials listed in the annexes of the London Dumping Convention are found during the survey, the dredged material should be treated in accordance with the respective provisions of the convention (See appendix 4). Selection of disposal site, disposal methods and requirements for capping are key issues in undertaking disposal at sea. In shallow water, silt curtains, as well as careful selection of the dredging method, could be effective in minimizing dispersal of resuspended sediments. Specific Guidelines for the Disposal of Dredged Material at Sea have been adopted by the Contracting Parties to the London Dumping Convention.

## **2.2.4 Potential impacts on marine/coastal ecology (B4 of table 2.1)**

Disturbance from construction activities may cause displacement of fishery resources and other mobile bottom biota. Dredging removes bottom biota and dumping of dredged material covers bottom habitat, both of which may reduce fishery resources. Settlement of resuspended sediments on fragile marine fauna and flora damages the ecosystem particularly coral reefs, which are formed by the extracellular product of symbiotic plants. The great number of coral polyps attached need dissolved oxygen for respiration and the plants need sunlight for photosynthesis.

Piles, concrete surfaces, rubble mounds and other similar structures in water could form new habitats, which may introduce undesirable species. If toxic substances and other contaminants are resuspended through dredging or dumping, they may lead to contamination of fishery and shellfishery resources.

### **Measures against adverse effects**

Careful survey of a fragile marine and coastal ecology is essential for appropriate planning of construction work, dredging, and disposal of dredged material. Selection of port site is the key to minimizing adverse effects (subsection 2.1.4). Since adverse effects usually result from bottom contamination and deterioration of water quality, measures against those adverse effects noted in subsections 2.2.1 to 2.2.3 are also effective for mitigating changes in aquatic and terrestrial habitat.

### **2.2.5 Potential impacts on air quality (B5 of table 2.1)**

Emissions from construction equipment, work vessels, trucks and other vehicles used in construction work could be a source of air pollution. Dust from construction activities is also a possible source of air pollution.

#### **Measures against the adverse effects**

Methods for controlling dust emission are water scattering in the construction site, use of proper transport methods, such as a conveyor belt, for excavated material and screens around the construction site. A green belt zone or open space between the construction site and the local community could be an effective buffer. Temporary pavement of roads in a construction site could considerably reduce dust emission.

### **2.2.6 Noise and vibration (B6 of table 2.1)**

Construction activities may create a problem of noise and vibration generated by construction equipment, truck traffic, work vessels and other similar sources.

#### **Measures against adverse effects**

Transmission of noise and vibration are limited by the distance from their sources. Noise could be considerably reduced by adoption of low noise equipment or installation of sound insulation fences. Green belt of plants can be a good barrier. Limitation of working hours may be a possible means to mitigate the nuisances of construction activities.

### **2.2.7 Waste management (B7 of table 2.1)**

Wastes from construction activities are mainly spoils generated by dredging. Disposal of dredged material on land may cause destruction of plants, loss of vegetation, leakage of contaminated materials and salt, odour, an unsightly view and other nuisances to the local community. Disposal in water may cause problems identified in subsection 2.2.3.

#### **Measures against adverse effects**

The adverse effects of disposal of contaminated dredged material or other wastes from construction activities could be offset by including them in land reclamation. Appropriate design, according to the characteristics of the wastes, is a basic requisite for retaining walls, settling ponds, capping of landfills, and land use after completion.

Dumping of dredged materials should be treated in accordance with the provisions of the Convention on the Prevention of Marine Pollution by Dumping of Wastes and Other Matter, 1972, and the Amendments Adopted in 1978 and 1980, the so called London Dumping Convention, and relevant national regulations (Appendix 4). For some regions specific Conventions or Protocols have been adopted, e.g. the SPDEP, Convention covering the South Pacific.

## **2.3 IMPACTS OF SHIP TRAFFIC AND DISCHARGES**

### **2.3.1 Potential impacts on water quality (C1 of table 2.1)**

Possible discharges from ships that could be sources of water pollution are bilge water, ballast water, oily wastes, sewage, garbage and other residues in a ship. Spills of oils, lubricants, fuels and other oily liquids may be other sources of water pollution. Once an oil or oily compound is discharged into water, it is spread on the surface by winds and currents, forming a thin layer. On the surface of seas in tropical or temperate zones, oils can be polymerized gradually by biodegradation and eventually form dense particles which sink.

Concentration of oily compounds in water is an important indicator of water quality, particularly in recreational water areas. Repair docks may be a possible source of toxic or harmful materials such as antifoulants, paints, or heavy metals.

#### **Measures against adverse effects**

Appropriate regulations on ship discharges and provision of reception facilities are indispensable for proper control of emissions and effluent from ships. Detection of spills is also important for regulating ship discharges. Since accidental spills are unavoidable, recovery vessels, oil fences, and treatment chemicals should be prepared with a view to minimizing dispersal. Proper contingency plans and a prompt reporting system are keys to prevention of oil dispersal. Periodical clean-up of floating wastes is also necessary for preservation of port water quality.

### **2.3.2 Potential impacts on marine and coastal ecology (C4 of table 2.1)**

Leakage of oils, oily wastes and mixtures may directly cause damage to fishery resources, aquatic biota and coastal habitat. Biodegradation of oil also generates polymerized oil particles and toxic aromatic fractions using dissolved oxygen in the water, which indirectly cause damages to bottom biota and habitat. Both effects may seriously damage marine and coastal ecology.

Fishery resources, including shellfish, may be spoiled by oil and toxic substances generated by biodegradation. Some oils contain carcinogens and their contamination is reported in fishery resources.

#### **Measures against adverse effects**

See subsection 2.3.1.

### **2.3.3 Potential impact on air quality (C5 of table 2.1)**

Ships are a possible source of airborne emissions such as gasses, smoke, soot and fumes. NO<sub>2</sub> and SO<sub>2</sub> are typical pollutants generated by ships while both manoeuvring and berthing and may affect air pollution in the hinterland.

#### **Measures against adverse effects**

Regulation and proper detection of emissions from ships are effective means to reduce discharges of pollutants. Prohibition of the use of heavy diesel oil as fuel could be a possible means to reduce pollutants. If the basic level of air pollution is considerably high, measures against air pollution should be planned on a regional basis, including port activities.

### **2.3.4 Waste management (C7 of table 2.1)**

Ships generate: (a) oily wastes such as bilge water, ballast water, washing water, lubricant oil and other residues in machinery space; (b) sewage and garbage; and (c) cargo residues such as wood bark. Discharges and spills of these wastes cause problems of oil pollution, floating garbage, unsanitary conditions, odour and other degradation of water quality.

#### **Measures against adverse effects**

Ports are requested to provide sufficient reception facilities to receive residues and oily mixtures generated from ship operations according to provisions of the International Convention for the Prevention of Pollution from Ships, 1973 (MARPOL, 1973) as amended by the 1978 Protocol (MARPOL, 1973/78). Besides oily residues, reception of sewage and garbage is also required in accordance with the needs of calling ships. Connection to sanitary treatment facilities or a municipal waste treatment system may be a means for a port to receive such wastes.

Provision of these facilities, promulgation of regulations on discharge of oily residues, and proper detection are keys to successful control of ship discharges. Unsanitary discharges from repair docks should also be connected to appropriate waste treatment systems.

### **2.3.5 Socio-cultural Impacts (C9 of table 2.1)**

Oil and oily wastes discharged from ships may reach nearby beaches and spoil recreational activities which cause serious damage to tourism. Ship traffic may disturb pleasure boat cruising and fishery boat operations. The possibility of accidents in the ship traffic becomes a worry to local people. Ship calls create many related jobs including pilotage, tug services, stevedoring, bunker and crew services, however, they may bring considerable changes in the life style of local people.

#### **Measures against adverse effects**

See subsection 2.1.6. In addition, appropriate regulations on ship traffic and discharges and contingency plan for ship accidents could mitigate the problem.

## **2.4 IMPACTS OF CARGO OPERATIONS AND WATERFRONT INDUSTRY**

### **2.4.1 Impacts on water quality (D1 of table 2.1)**

Runoff from raw material storage, spills from bulk cargo handling, and wind-blown dust are possible sources of contamination of port water. Toxic or harmful substances may be included in runoff from sulfur, bauxite, phosphates, nitrogenous manure, coal, metal ores and other raw materials. Organic materials in runoff are decomposed to the inorganic form, spending dissolved oxygen and increasing the nutrient level in water. Accidental spills of toxic, harmful materials, oils or oily compounds, and other raw materials are also possible sources of contamination of water.

Effluent from waterfront industries may include toxic or harmful materials, unsanitary wastes, oily wastes and other hazardous materials. Electricity generation may release heated water and sewage treatment facilities produce nutrient salts, organic matter and some hazardous materials.

**Measures against adverse effects**

Countermeasures against runoff are: (a) covering or enclosing raw material storage areas; (b) sprinkling water on raw material except anti-humid materials like grains or cement; (c) providing special equipment for cargo handling and transport (e.g., covered conveyor or pneumatic unloader); and (d) other methods to reduce the influence of wind and rain.

A reversed slope apron is an effective means to avert rainfall from washing away from the apron and pouring into the sea directly. The drains from the apron are led to a settling pond and released into the sea after settlement of suspended materials.

Regulations on effluent from waterfront industries and monitoring of water quality are essential for port environment protection. Separation of waterfront industry discharges from the harbour area could be an effective means to offset problems caused by such effluent.

**2.4.2 Potential impacts on bottom contamination (D3 of table 2.1)**

Bottom contamination may result from runoff from quay and storage area, spills from bulk cargo operations, and wind blown dust. Discharge from waterfront industries is a major source of contamination of bottom sediments.

**Measures against adverse effects**

See subsection 2.4.1.

**2.4.3 Potential impacts on marine and coastal ecology (D4 of table 2.1)**

Cargo handling and storage may cause runoff, spills or leakage of ingredients, which possibly include toxic or harmful materials, organic matter, or oily compounds. Water pollution and bottom contamination resulting from these effluents lead to deterioration of aquatic biota and fishery resources. Dust dispersion on land may cover plants and change terrestrial habitat. If toxic or harmful substances are included in dust emissions, the health of port workers and local people are endangered.

Discharge from waterfront industries is a major source of water pollution which induces deterioration of aquatic biota due to toxic and harmful materials, poor oxygen dissolution and eutrophication of water. See subsections 2.1.4. and 2.2.4.

**Measures against adverse effects**

See subsection 2.3.1.

#### **2.4.4 Potential impacts on air quality (D5 of table 2.1)**

Emissions of dust from bulk cargo handling and gasses from cargo handling equipment can be sources of air pollution. Liquid cargo handling may result in the release of vapour during the cleaning of storage tanks and by the breather system for ambient temperature changes. Accidental leakage of gasses may cause problems such as toxic material emission, explosions, fumes, odours and hazardous airborne emissions. Waterfront industries may release various kinds of gasses and can be major sources of air pollution and odour.

##### **Measures against adverse effects**

Monitoring of air quality is indispensable to ensure acceptable levels of emissions. Dust emission can be reduced by covers, screens, enclosures, sprinkling water or other similar methods. Regulations on emissions from waterfront industries should be introduced in accordance with a regional environment management plan.

#### **2.4.5 Noise and vibration (D6 of table 2.1)**

Cargo handling equipment and road traffic are two major sources of noise and vibration, which may cause unacceptable levels of stress among local people.

##### **Measures against adverse effects**

See subsection 2.2.6

#### **2.4.6 Waste management (D7 of table 2.1)**

Cargo operations produce wastes such as the remains of bulk cargo storage, rubbish from unpacking, wood bark from log handling, floating garbage and other wastes from daily activities. Waterfront industries generate various kinds of wastes and some of them are disposed of in the port area or at sea. Landfills in a port area could be deposition sites of such industrial wastes.

##### **Measures against adverse effects**

According to the need of a port, facilities for the incineration of wood bark should be provided at the port site. Remains of bulk cargo storage or industrial wastes which are not considered hazardous can be deposited in land reclamation sites where retaining walls are designed against leakage of toxic or harmful substances. Sewage or garbage from port activities can be handled by a municipal treatment system or by the port's own treatment facilities.

#### **2.4.7 Potential impacts on visual quality (D8 of table 2.1)**

Lighting for night operations may cause nuisances to the nearby community. Wastes from port-activities, smoke from ships, bulk cargo piles, and ugly materials stacked in a port may give an unpleasant impression.

##### **Measures against adverse effects**

Appropriate selection of the location of port can mitigate these adverse effects on visual quality. It may be possible to design storage areas blinded from roads or the nearby

community. A green belt zone around a port may block an unpleasant view and moderate unpleasant sight. Relocation of busy area is a possible means to reduce excess lighting.

#### **2.4.8 Socio-cultural impacts (D9 of table 2.1)**

Port activities may result in the hiring of local labour and procurement of various commodities from a local market. The local economy will be boosted by port-related activities and be greatly involved in urbanization and industrialization. Labour from outside may be a possible source of conflict with a local community.

##### **Measures against adverse effects**

See subsection 2.1.6

### **2.5 CHECK LISTS OF POTENTIAL ADVERSE EFFECTS**

The World Bank released a technical paper entitled Environmental Considerations for Port and Harbor Developments in 1990, which contains a check list of the potential adverse effects port development may create (Appendix-1). The Asian Development Bank (ADB) also has a publication entitled Environmental Guidelines for Selected Infrastructure Projects, which includes a check list of Environmental Parameters of Port and Harbor Projects (Appendix-2). The International Association of Ports and Harbours has also released the IAPH Guidelines for Environmental Planning and Management in Ports and Coastal Area Developments, 1989, which includes a check list of potential adverse effects of port development (Appendix-3).

The ADB's check list categorizes environmental resources concerning port development into the following types: (a) Coastal marine ecology; (b) Recreation/Resort/Beach areas; (c) Sanitation in harbor area; (d) Hazardous cargo; (e) Materials to and from harbour; (f) Local socio-economics, etc., and has an indication of feasible protection measures against each action. The Japanese Transport Ministry also furnishes a check list of environmental impacts concerning port development, which is classified from a viewpoint of environmental components, viz. water quality, air quality, living characteristics (noise, odour, vibration, etc.) topographical features, oceanographical features, hazardous material contamination, natural habitat (land and marine), landscape, and socio-cultural features.

As indicated in these check lists, the potential adverse effects of port development embrace a wide range of environmental issues like water pollution, contamination of bottom sediment, loss of bottom biota, damage to fisheries, beach erosion, current pattern changes, waste discharges, waterfront drainage, oil leakage and spillage, hazardous materials, emissions of dust and gases, smoke and other air pollution, noise, odour, traffic increases, landfills, landscape, socio-cultural impacts, and so forth.

These probable adverse effects of port development are usually assessed by the magnitude of impacts, however, there is no established criteria to evaluate whether or not these adverse effects fall within an acceptable range as such criteria will vary by countries or ports depending on local and regional characteristics. In case the background pollution levels in a project area exceeded their standards, a development project could be evaluated from a viewpoint whether the project is included in the environment management plan of the region. Evaluation procedures are the key to successful implementation of EIA.

### 3 ENVIRONMENTAL INDICATORS AND CRITERIA

The permissible levels of pollution in port environments vary from port to port, according to their geographical location and the requirements of the local community. The permissible levels of one port are not necessarily appropriate for another port because of differences in the environmental situations. Each port should have its own environmental objectives and permissible pollution levels in view of the existing levels of pollution, types of pollution sources, and future development plans. Permissible limits in this chapter indicate examples of regulations on typical indicators of the quality of the environment in countries of the ESCAP region.

#### 3.1 WATER QUALITY AT SEA

Typical environmental indicators of water quality at sea are listed in table 3.1 with a short explanation of their characteristics. Chemical Oxygen Demand (COD), Biochemical Oxygen Demand (BOD), Dissolved Oxygen (DO), the degree of acid/alkaline (pH), coliform bacteria and oil content are major indicators of the water quality at sea. Their permissible limits in various countries are as shown in table 3.2. A range of each indicator is comparatively small, however, limits for heavy metal contents and organic matter deviate rather widely.

While survey on water quality in port and contamination of the seabed are usually undertaken in the process of EIA for development project, periodical monitoring of port water quality is not a common practice in developing countries, yet in order to analyze seasonal changes or errors in data, a series of monitoring data is indispensable. Careful monitoring of the quality of effluent discharge into river, sea or other water areas is also indispensable for improving and preserving the quality of port water. Guidelines for monitoring seawater and various analytical guidances have been developed by UNESCO/IOC and UNEP.

#### 3.2 BOTTOM CONTAMINATION

Amount of organic matter is an indicator of contamination of bottom sediments and measured by COD, BOD or Ignition Loss total organic carbon (TOC) in an unit of sediment. Harmful substances such as sulphide or heavy metals are another indicator of bottom contamination (table 3.3). Black sediments are a sign of hydrogen sulphide, which is produced under anaerobic conditions, and is a signal of the progress of contamination of the sea bottom. It is also a sign that heavy metals, pesticides, or other harmful substances may have accumulated in bottom sediments. Dissolution of harmful substances in bottom sediments and oxygen demands for decomposing organic matter are also necessary factors for bottom contamination survey.

The London Dumping Convention<sup>1</sup> prohibits the dumping of wastes or other matter listed in Annex I and requests special permission for the dumping wastes or other matter listed in Annex II of the Convention. Since the provision of the Annex II is that "the dumping of wastes containing significant amounts of the matters listed below" requires a prior special permission, it is necessary to indicate permissible limits for those substances.

---

See Appendix 4

Canada and United States of America initiate permissible limits for offshore dumping of dredged material as shown in table 3.4. If dredged material is contaminated beyond the limits, it should not be dumped in the sea. Japan has also established criteria for harmful bottom sediments (table 3.5), which must be specially treated before being used for filling in land reclamation.

In addition to regulations on offshore dumping, Japan has established provisional criteria for contaminated sediments by mercury and polychlorinated biphenyl (PCB) that should be dredged and deposited in a special landfill. The criteria for the removal of sediments contaminated by mercury is 25 ppm in case of rivers and the value given by the equation in appendix 5 in case of the sea. The criteria for the removal of PCB is 10 ppm in both the sea and rivers.

### 3.3 AIR QUALITY

Typical indicators of air quality are sulfur dioxide (SO<sub>2</sub>), nitrogen dioxide (NO<sub>2</sub>), carbon monoxide (CO), suspended particulate matter (SPM) and oxidant. Short explanations of these indicators are listed in table 3.6 and their permissible levels are shown in table 3.7.

Regulations on the emission of air and water pollutants from industrial activities have been introduced in many countries. Air pollutants from ships, however, are generally not yet regulated like those from factories except visual smoke and dust emission. To reduce the emission of SO<sub>2</sub> from ships, a few port have prohibited the use of type-C heavy diesel oil. Efforts are being made by the International Maritime Organization (IMO) to regulate globally emissions from ships.

### 3.4 NOISE

Regulations on noise levels generally vary according to the type of land used and the time of day. Five examples of noise regulations in countries of the region are summarized in table 3.8. Permissible noise levels in a light industry area, probably port area, appear to be 60 - 70 dBA<sup>2</sup>.

### 3.5 ODOUR

Cargo handling and storage could be a source of offensive odours. Typical odour generating substances are listed in table 3.9 with a short description of the characteristics. Few countries have established permissible levels for such substances and Japanese regulations are shown in the table as an example.

---

<sup>2</sup> Degree of measurement of noise, which is calculated by measuring the sound pressure. The scale is further refined according to an A, B, C system, the dBA being the most used because it is the hearing level of humans. (Reference 15)

**TABLE 3.1 Water-related indicators**

---

**Chemical oxygen demand (COD):**

Non-biological uptake of molecular oxygen by organic and inorganic compounds in water. A principal indicator of eutrophication.

**Biological oxygen demand (BOD):**

The rate of oxygen consumption by organisms during the decomposition (respiration) of organic matter, expressed as grams oxygen per cubic metre of water. BOD during five days under 20°C is called BOD<sub>5</sub>. A principal indicator of eutrophication.

**pH:**

A measure of the concentration of hydrogen ions of a substance, which ranges from very acid (pH = 1) to very alkaline (pH = 14). pH 7 is neutral and most waters range between 6 and 9. It varies with photosynthetic activity and generation of organic acid and hydrogen sulphide, as well as man-made impacts.

**Suspended solid (SS):**

An amount of particles with long setting rates of any solid in water including inorganic particles, plankton and organic debris (= detritus), expressed as milligrams per liter (= ppm).

**Dissolved oxygen (DO):**

The concentration of oxygen dissolved in water. An indicator of critical importance to survival of aquatic organisms. This decreases with decomposition of organic matter and increases with photosynthesis.

**Numbers of coliform group:**

Numbers of *Escherichia* in water, expressed as most probable number per 100 ml. *Escherichia* is a group of bacteria commonly found in faeces, and its occurrence in water indicates the pollution by sewage, although *Escherichia* itself may not cause any illness.

**Oil content:**

An indicator of oil pollution, commonly expressed as milligrams of normal-hexane extracts per liter. Usually caused by a damaged oil tanker, oil spill from ships (bilge water, oily ballast water, etc.) and other facilities on land.

**Water temperature:**

A basic indicator influencing the activity of enzyme and consequently the metabolic rate of organisms.

**Transparency:**

The ability of water to transmit sunlight. Measured with a Secchi disc, which is a white disc with a diameter of 25 - 30 cm, that is placed in the water to record the maximum depth (m) at which the disc can be seen.

**Chlorinity:**

A measure of the chloride and other halogen content, by mass, of sea water, expressed as milligrams per liter.

**Nitrogen (N) and phosphorus (P):**

Major indicators of nutrient salts for growth of aquatic plants. They play an important role to increase the biomass of plankton and lead to eutrophication. Existing in both organic and inorganic forms, and converted to the other form through the nitrogen cycle and the phosphorus cycle.

**Chlorophyll-a:**

A type of chlorophyll present in all type of algae, sometimes in direct proportion to the biomass of algae. Essential for the conversion of sunlight, carbon dioxide, and water to sugar and oxygen. Sugar is then converted to starch, proteins, fats and other organic molecules.

**Algal growth potential (AGP):**

An indicator of eutrophication obtained with a bioassay test which investigate the primary productivity of phytoplankton using water sampled from the study area.

**Phenol:**

Used principally in manufacturing synthetic resins and weed killers. Regarded as an odorizing material to drinking water and tainting aquatic products.

**Total organic carbon (TOC):**

The amount of carbon contained in organic matter (dissolved organic matter, organic debris and plankton) in water.

**Total oxygen demand (TOD):**

An indicator of consumption of oxygen in water, which can detect the oxygen consumption by nitrogen compounds that are ignored in measurements of BOD or COD.

**TABLE 3.2 Permissible levels of water quality indicator**

Country	Purpose/place	Indicator					
		pH	DO (mg/l)	COD (mg/l)	BOD (mg/l)	Oil (mg/l)	Coliform bacteria (MPN/100ml)
<i>India</i>	Polluted area						
	Recreation	6.5 - 9.5	≥3	-	≤5	≤0.1	≤1,000
	Harbour	6.5 - 9.0	≥4	-	≤5	≤10	≤2,500
	Non-polluted area						
	Bathing	-	≥5	-	≤3	-	≤500
	Aquatic biota	-	≥4	-	≤6	-	≤500
<i>Indonesia</i>	Coastal water						
	Bathing	6.0 - 9.0	≥5	≤40	≤20	≤3	≤1,000
	Aquaculture	6.0 - 9.0	≥4	≤80	≤45	≤5	≤1,000
	Marine park	6.0 - 9.0	≥4	≤80	≤45	≤5	≤1,000
	Industry	6.0 - 9.0	-	≤40	≤20	≤2	≤1,000
<i>Japan</i>	Sea						
	Bathing	7.8 - 8.3	≥7.5	≤2	-	≤0.5	≤1,000
	Industry (B)	7.8 - 8.3	≥5	≤3	-	≤0.5	-
	Industry (C)	7.0 - 8.3	≥2	≤8	-	-	-
<i>Malaysia</i>	Sea						
	Natural	6.5 - 8.5	≥7	≤10	≤1	ND	≤100
	Aquatic biota	6.0 - 9.0	5 - 7	≤25	≤3	-	≤5,000
	Recreation	6.0 - 9.0	5 - 7	≤25	≤3	-	≤5,000
	Common	5.0 - 9.0	3 - 5	≤50	≤6	-	≤50,000
<i>Philippines</i>	Sea						
	Recreation	6.5 - 8.5	≥5	-	-	≤2	≤1,000
	Aquatic biota	6.5 - 8.5	≥5	-	-	≤5	≤5,000
	Industry	6.5 - 8.5	≥3	-	-	≤5	-
	Navigation	5.0 - 9.0	≥2	-	-	≤10	-
<i>Thailand</i>	Bay						
	Swimming	6.5 - 8.3	≥4	-	-	ND	≤1,000
	Conservation	7.5 - 8.9	≥5	-	-	ND	-

ND: Not detectable

Source: References 1 - 11

TABLE 3.3 Substances of Bottom Contamination

---

**Cadmium (Cd):**

A metallic element, often used in the plating of iron, steel and other metals. It also used in industries of ceramics, cosmetics, etc. Principal discharge sources of cadmium are industries of plating of iron and steel, alloys, ceramics, cosmetics and camera films, mines and refineries of zinc and lead. Its contamination to rice once caused a serious disease in Japan.

**Cyanogen compounds (CN):**

Including highly toxic substances which cause death of aquatic animals and stoppage of uptake of drinking water.

**Organophosphorus:**

Included in pesticides and posing a serious threat to human health. Organophosphorus pesticide together with organochlorine pesticide is a major component of agricultural chemicals.

**Lead (Pb):**

Very heavy soft metallic element. Used principally in alloys in pipes, cable sheaths, batteries type metal and shields against radioactivity.

**Chromium (VI) (Cr<sup>6+</sup>):**

Used principally in chrome plating, in chromizing, and in many alloys. Toxic.

**Arsenic (As):**

Used mainly in manufacturing insecticides, rodenticide and medicines. Toxic.

**Total mercury (T-Hg):**

Including R-Hg and inorganic mercury. Toxic.

**Alkylmercury (R-Hg):**

Organic compound of alkyl and mercury. Virulently toxic. Used principally in manufacturing pesticides.

**Polychlorinated biphenyl (PCB):**

Stable compound. Extensively used in electrical fittings and paints. Although they are no longer manufactured, they are extremely persistent and remain in huge quantities in the atmosphere and in landfill sites. They are eaten by aquatic animals and enter the food chain. Toxic.

**Copper (Cu):**

A metallic trace element, essential to biological life and used mainly in making alloys and in electric wiring. In large amounts toxic to marine life.

**Zinc (Zn):**

A metallic trace element, essential to biological life, principally used in alloys and as a protective coating for steel.

**Iron (Fe):**

A metallic element, essential to biological life and an essential part of human diet.

**Manganese (Mn):**

A metallic element, essential to biological life, used mainly in making steel.

**Fluorine (F):**

A chemical element, highly toxic, used as a strong oxidizing agent.

---

**TABLE 3.4 Permissible limits for offshore dumping of dredged material**

(unit: ppm or ppb)

Substance	Canada	USA
PCB (ppb)	100	380
Hg (ppm)	0.75	0.15
Cd (ppm)	0.60	0.7
Zn (ppm)	169	105
Cu (ppm)	45	68
As (ppm)	(5 - 25)	12.5
Pb (ppm)	45	33
Organochlorine pesticide (ppb)	10 for any compound	5.0 Sum of DDT, DDE and DDD
Polyaromatic hydrocarbon (ppb)	(1,000) Sum of 16 compounds	680 Sum of six low mol. wt. compounds 2,690 Sum of 10 high mol. wt. compounds

Note: Figures in parentheses are proposed limits.

Source: Macknight, S. et al. (1989) The Environmentally Sound Disposal of Dredged Materials. Technical paper, Infrastructure and Urban Development Department, The World Bank.

**TABLE 3.5 Criteria for harmful bottom sediments (Japan)**

(unit: mg/l)

Contaminated material	Dumping in landfills mg/l	Dumping at sea mg/l
Alkylmercuric compounds	not detectable	not detectable
Mercury and its compounds	0.005	0.005
Cadmium and its compounds	0.1	0.1
Lead and its compounds	1	1
Organophosphorus compounds	1	1
Chromium (VI) compounds	0.5	0.5
Arsenic and its compounds	0.5	0.5
Cyanogen compounds	1	1
PCB	0.003	0.003
Copper and its compounds	-	3
Zinc and its compounds	-	5
Fluoride	-	15

Note: Criteria are based on the examination of dissolution of contaminated materials

Source: Kankyo Roppou, 1990, Environmental Agency, Japan

TABLE 3.6 Air-related indicators

**Sulphur oxides (SO<sub>x</sub>):**

An oxide of sulphur, such as sulphur dioxide (SO<sub>2</sub>) and sulphur trioxide (SO<sub>3</sub>). Generated principally with combustion of heavy oil. Usually coexisting with suspended particulate matter and causing a lesion of respiratory organ or mucosae.

**Carbon monoxide (CO):**

Formed with incomplete combustion, causing a lesion of oxygen supply capacity of man.

**Suspended particulate matter (SPM):**

Including soot and dust with a diameter of 10 μm or less generated mainly with combustion and suspended in ambient atmosphere. Causing a lesion of respiratory organ.

**Photochemical oxidant (Ox):**

Any of the chemicals which enter into oxidation reactions between nitrogen oxides and hydrocarbon in the presence of light or other radiant energy. Causing a lesion of mucosae of the respiratory organ.

**Nitrogen oxides (NO<sub>x</sub>):**

Oxides formed through direct combination of nitrogen and oxygen in air during combustion, such as nitrous oxide (NO) or nitrogen dioxides (NO<sub>2</sub>). Causing a lesion of respiratory organ or mucosae.

**Cadmium and its compounds:**

Principal emission sources of cadmium are furnaces of copper, lead and zinc refinery, cosmetic manufacturing. Causing a stimulation to nose and throat, headaches, giddiness, nausea and more serious disease.

**Chlorine and its compounds:**

Principal emission source is leakage from factories using or making chlorine or hydrogen chloride. Causing a stimulation to nose and throat, a lesion of respiratory organ, amblyopia and deterioration of dentine.

**Lead and its compounds:**

Principal emission sources of lead are furnaces of copper, lead and zinc refinery, and of factories manufacturing lead products, glass, lead batteries, and exhaust gas of motor vehicles. Causing arthralgia, muscular pain, motor disturbance, headaches, giddiness and a lesion of a nerve center.

**Fluorine and its compounds:**

The biggest emission source is a aluminum electrolysis factory. Factories manufacturing phosphatic fertilizer and glass are also responsible.

**Dust:**

Fine powder made of particles of dry dirt or sand of any size. Originated from open deposit of ore and other dry bulk cargoes, construction works and road traffic. Effects on human health may be similar to those of SPM.

**Hydrocarbon (HC):**

Principal emission source are leakage from oil storage/handling facilities and volatilization from oily products and organic solvent.

**Other harmful air pollutants:**

The following substances generated with industrial activities may have adverse effects on life and the living environment: ammonia (NH<sub>3</sub>), hydrogen fluoride (HF), hydrogen cyanide (HCN), carbon monoxide (CO), formaldehyde (HCHO), methanol (CH<sub>3</sub>OH), hydrogen sulphide (H<sub>2</sub>S), hydrogen phosphide (PH<sub>3</sub>), hydrogen chloride (HCl), nitrogen dioxide (NO<sub>2</sub>), acrolein (CH<sub>2</sub>CHCHO), sulphur dioxide (SO<sub>2</sub>), chlorine (Cl<sub>2</sub>), carbon disulphide (CS<sub>2</sub>), benzene (C<sub>6</sub>H<sub>6</sub>), pyridine (C<sub>5</sub>H<sub>5</sub>N), phenol (C<sub>6</sub>H<sub>5</sub>OH), sulphuric acid (H<sub>2</sub>SO<sub>4</sub>) including sulphur trioxide (SO<sub>3</sub>), silicon fluoride (SiF<sub>4</sub>), phosgene (COCl<sub>2</sub>), selenium dioxide (SeO<sub>2</sub>), Chlorosulphonic acid (HSO<sub>3</sub>Cl), yellow phosphorus (P<sub>4</sub>), phosphorus trichloride (PCl<sub>3</sub>), Bromine (Br<sub>2</sub>), nickel carbonyl (Ni(CO)<sub>4</sub>), phosphorus pentachloride (PCl<sub>5</sub>) and mercaptan (C<sub>n</sub>H<sub>m</sub>SH)

TABLE 3.7 Permissible levels of air quality indicators

Country/Area/ Int'l organization	SO <sub>2</sub> (µg/m <sup>3</sup> )		NO <sub>2</sub> (µg/m <sup>3</sup> )		SPM (µg/m <sup>3</sup> )		CO (mg/m <sup>3</sup> )		Oxidant (µg/m <sup>3</sup> )
	1 hr.	24 hr.	1 hr.	24 hr.	1 hr.	24 hr.	1 hr.	8 hr.	1 hr.
<i>China</i>	150- 700	50- 250	100- 300	50- 150	150- 700	50- 250	10-20	-	120-200
<i>Indonesia</i>	-	260	-	92.5	-	260	-	22.6	200
<i>Hong Kong</i>	800	350	300	150	-	180	30	10	240
<i>Japan</i>	286	114	205- 409	82- 123	200	100	-	25	129
<i>Malaysia</i>	-	-	-	-	-	75	-	-	-
<i>Philippines</i>	850	369	190	-	250	180	35	10	120
<i>Republic of Korea</i>	-	429	307	-	-	300	-	25	214
<i>Thailand</i>	-	300	320	-	-	330	50	20	200
<i>WHO</i>	350	100- 150	400	150	-	150	30	10	150-200
<i>World Bank</i>	-	-	-	-	-	500	-	-	-

Note: 1 hr. = one hour average; 24 hr. = twenty-four hour average;  
Source: References 1 - 11

TABLE 3.8 Regulations on the maximum permissible levels of noise

Country	Light industry area			Residential area		
	Day	Morning/ Evening	Night	Day	Morning/ Evening	Night
<i>Indonesia</i>	70			60		
<i>Japan</i>	60	55	50	50	45	40
<i>Philippines</i>	70	65	60	55	45	40
<i>Republic of Korea</i>	-			60 - 65		
<i>Sri Lanka</i>	63	60	55	50	45	40

unit: decibel (dBA)  
Source: References 1 - 9

TABLE 3.9 Odour-related indicators and permissible levels

Substance	Characteristics of odour (Molecular formula)	Permissible levels (ppm)	Likely sources
Ammonia	Irritating odour (NH <sub>3</sub> )	1 - 5	Livestock, drying yard of fowl dropping, fertilizer manufacturing, meat and fish processing
Methyl mercaptan	Putrid smell of onions (CH <sub>3</sub> SH)	0.002 - 0.01	Starch manufacturing, kraft pulp manufacturing, medicine manufacturing, oil refinery, refuse disposal plants, sewage treatment plants
Hydrogen sulphide	Putrid smell of eggs (H <sub>2</sub> S)	0.02 - 0.2	Starch manufacturing, kraft pulp manufacturing, medicine manufacturing, oil refinery, refuse disposal plants, sewage treatment plants
Methyl sulphide	Putrid smell of cabbages ((CH <sub>3</sub> ) <sub>2</sub> S)	0.01 - 0.2	Kraft pulp manufacturing, medicine manufacturing, oil refinery, refuse disposal plants, sewage treatment plants
Methyl disulfide	Putrid smell of cabbages ((CH <sub>3</sub> ) <sub>2</sub> S <sub>2</sub> )	0.009 - 0.1	Kraft pulp manufacturing, medicine manufacturing, oil refinery, refuse disposal plants, sewage treatment plants
Trimethylamine	Putrid smell of fish ((CH <sub>3</sub> ) <sub>3</sub> N)	0.005 - 0.07	Livestock, fertilizer manufacturing, meat and fish processing, canning factories of fish
Acetaldehyde	Irritating odour like ether (CH <sub>3</sub> CHO)	0.05 - 0.5	Acetaldehyde manufacturing, acetic acid manufacturing, tobacco manufacturing, fertilizer manufacturing, meat and fish processing
Styrene	Offensive odour of solvents (C <sub>8</sub> H <sub>5</sub> CH <sub>2</sub> CH)	0.4 - 2	Styrene manufacturing, polystyrene manufacturing/processing, FRP manufacturing, facing plywood manufacturing

Source: Technical manual of EIA of port development, 1983, Ministry of Transport, Japan

## 4 METHODS FOR SURVEY AND IMPACT PREDICTION

### 4.1 WATER POLLUTION

Major indicators of water pollution are COD, BOD, nitrogen, phosphorus, dissolved oxygen (DO), oil, suspended solids (SS), heavy metals and pesticides. A survey of these pollutants is undertaken as the first part of an environmental impact assessment. Secondly, the existing condition is analyzed in comparison with permissible levels of pollutants where available. Thirdly, impacts on the environment are predicted by modelling the future situation and activities.

#### 4.1.1 Survey of water pollution

##### 4.1.1.1 Observation

General observation of the water area is indispensable for tracing the boundary of freshwater influence in the sea in view of changes in water colour and waves. Occasional observations are indispensable to successfully survey of water pollution with relation to changes in meteorological conditions. If a distinct mass of stagnant water is recognized frequently in the adjacent area to the project site, it is likely that substances tend to accumulate in that area.

##### **Key to assessment**

Observations at the waterfront or on a boat assist in identifying oil film, floating garbage, suspended matter, other pollution on the surface, and the transparency of water. Transparency of water is measured by placing a secchi disk, a white disk with a diameter of 25-30 cm, in the water and checking the maximum depth of visibility. If visibility extends more than 3-4 metres deep, it indicates that water quality is good enough and eutrophication is not going on. If the color of water is whitish or brownish, municipal or industrial effluent may be a major source of pollution. Colouring phenomena may also be caused by the explosive growth of plankton resulting from eutrophication. Pictures from air or satellite are of great help in analyzing the spread of pollution.

##### 4.1.1.2 Sampling and analysis of water quality

Data on environmental indicators of water pollution change greatly depending on the season, time of day, tidal currents, local characteristics, place, layer in the sea, and even by sample. Errors in analysis are also unavoidable. Data should be checked to determine if it is consistent with data of former samples and nearby samples. Typical arrangements of sampling positions are shown in figure 4.1. If the depth of water is more than five metres, it is recommended to have samples from upper and lower layers. If several laboratories are involved an intercalibration exercise has to be carried out to ensure that results are compatible.

##### **Key to assessment**

Careful attention should be paid to seasonal variations and other deviations in data. Number, point, timing and method of sampling play a key role in obtaining reliable data. Salinity, DO, and the amount of the organic matter (BOD, etc.) are important indicators. Contamination by heavy metals is also an important factor in the case that industrial discharges flow into the study area. Nutrient salts (N, P) levels are indicators of eutrophication in a closed water area. Oil and coliform bacteria are requisite indicators of the amenity and sanitation in recreational water areas.

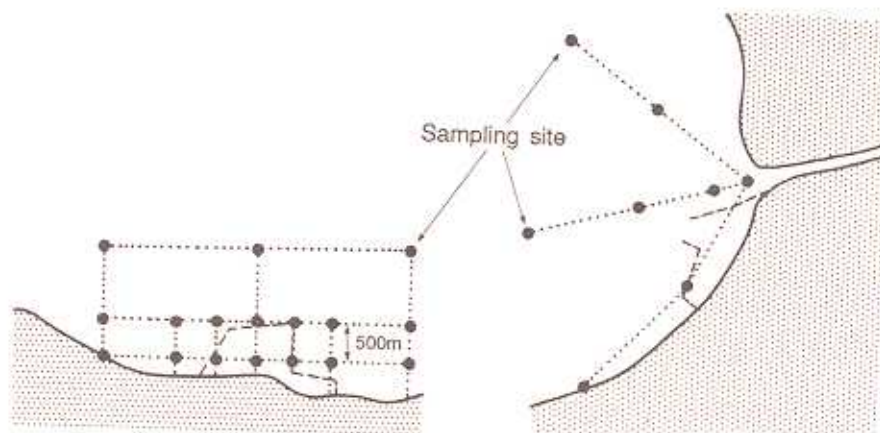

FIGURE 4.1 Typical points of sampling of water

#### 4.1.1.3 Estimation of the amount of pollutants

Total amount of pollutants poured into a particular water area is generally estimated from the population and industrial/agricultural activities in the catchment area. Factors which affect the amount of pollutants are as follows:

- (a) Population in the catchment area;
- (b) Size and type of factories;
- (c) Number of livestock in the basin; and
- (d) Land use and size (paddy fields, farms, forests, etc.).

Unit amount of pollutants discharged from settlements of people are shown in appendix 5 (2), where the measurement unit is gram per person a day. All pollutants generated from a catchment area do not flow into the water area since some of the pollutants are removed in the process of decomposition in the river, sewer or sewage treatment system. The rate of attainment, which is a ratio of pollutants generated from a catchment area and pollutants reaching water area, is estimated as shown in appendix 5 (1) in the case of BOD. The rate of attainment for T-N and T-P is about 100 per cent.

##### Key to assessment

The amount of pollutants from river or other discharges can also be estimated by multiplying the concentration ratio of pollutants in water and the volume of flow. There are usually considerable differences between this estimate and the above estimate, however, a reliable estimate will be obtained from mutual check of both estimates.

#### 4.1.2 Prediction of water pollution

Future amounts of pollutants are firstly estimated based on a possible assumption of population growth, economic growth, the design of the sewage treatment system installation, and regulations on effluent into rivers or the sea. Secondly, diffusion of pollutants is assessed

by models to predict future levels of water pollution. The following subsections introduce of methods for assessing the diffusion of pollutants in the sea.

#### 4.1.2.1 Nitta's experimental equation<sup>3</sup>

This method was developed from hydraulic experiments aiming at the estimation of the range of diffusion of freshwater from a river. The equation is very simple and the easiest way to estimate the area of diffusion of effluent into the sea, however, inclusive of considerable range of errors.

##### Key to the assessment

The equation shows an average of diffusion area. According to Nitta's observation, actual diffusion area is in a range of 34 per cent to 175 per cent of the average calculated by the equation.

#### 4.1.2.2 Joseph-Sendner's equation<sup>4</sup>

Joseph-Sendner's diffusion equation was developed to estimate the concentration at the distance of ( $r$ ) from the source when the concentration of discharged water ( $S_0$ ) at the outfall and the concentration of the background ( $S_1$ ) are given. Two basic assumptions on the equation are a continuous discharge of a certain amount of pollutants and a uniform diffusion to every direction in the semicircular area. The equation is therefore applicable to the estimation of pollution levels in water areas where the diffusion is not affected by current flow. The equation is shown in appendix 6 (2).

#### 4.1.2.3 Iwai-Inoue's equation

This equation was developed to supplement the Joseph-Sendner's equation and make it applicable to situations where a uniform stationary current flows from one side to another and pollutants are discharged at one point. A concentration level at any distance from the point of discharge can be obtained from this equation subject to certain condition of currents and tidal mixing. (Reference 17)

#### 4.1.2.4 Box mixing model

The box mixing model is suitable for a closed bay or port with an entrance from the sea and a width of up to 5 km. This model assumes that pollutants are poured in at some sections of the bay, water in each section is mixed in one tidal period (usually 12 hours), and pollutants in one section are conveyed to the next section by tidal flow. Inward flow conveys outer seawater and outward flow carries away pollutants. Some pollutants are carried back on the next inward flow. The model calculates the balance of pollutants in each section and seeks a concentration level where inflow and outflow of pollutants are equal. Usually COD or BOD is used as an indicator of pollutants.

---

<sup>3</sup> See, for instance, Hydraulic Formulas, Japan Civil Engineers Association, 1971

<sup>4</sup> Joseph J. and Sendner H., Über die Horizontale Diffusion im Meere, 1958

The idea of the box mixing model is shown in appendix 6 (3) and its equation is listed below the figure. Concentration level of each section ( $S_i$ ) is changed by the number of tides calculated but  $S_i$  converges to a certain level after a number of tides, which is likely an average of the concentration levels in each section.

Theoretically, it is possible to calculate  $S_i$  by assuming that the difference between  $S_i^m$  and  $S_i^{m-1}$  becomes zero where inflow and outflow of pollutants are balanced. The equation can be solved by a method of coalition linear equations.

#### 4.1.2.5 Computer simulation

Nitta's experimental equation, Joseph-Sendner's equation, Iwai-Inoue's equation and the box mixing model are useful to estimate an approximate level of pollutants in a certain condition but cannot give an accurate prediction in cases there are current flow and vertical flow in the water. Simulation is a method to imitate actual current flow and diffusion of pollutants and is easily done on a computer. A typical computer model is made by simplification of shoreline configuration, currents and tides as follows:

- Simulation area is represented by a group of land mesh and sea mesh. The size of each mesh is usually 500 - 2,000 m and each mesh has an uniform depth;
- Tidal elevation occurs on the outer seaside boundaries of the simulation area according to a formula;
- Water flow occurs from a mesh of high water level to adjacent low water meshes; and
- Pollutants spread following current flow and their own diffusion phenomena in water.

Coping with more complicated situations, many variations of simulation models have been developed, focusing on methods of representing the simulation area by meshes of different size and shape, or imitating vertical flow caused by the difference of temperature and salinity between surface water and bottom water.

The multi-layer simulation model is a model developed to simulate the difference between upper and lower layers, which is commonly found in areas like estuaries or where surface water is hot and current flow is less. In the case of eutrophic water, the multi-layer model is suitable for simulating the situation where photosynthesis is active in the upper layer and anaerobic dissolution of organic matter takes place in the lower layer without oxygen supply from the upper layer.

COD or BOD is usually selected as an indicator of water pollution. However, it is also important to simulate biological consumption of nutrient salts (N, P) and dissolved oxygen (DO) in polluted water and estimate the production of COD and BOD from this process (subsection 4.1.5).

#### 4.1.3 Dispersal of thermal discharge

Heated water discharged from power plants or factories spreads on the surface of the sea and its behaviour is different from the ordinary diffusion of pollutants. Computer simulation methods have been developed for analyzing the dispersal of thermal discharge as well as the diffusion of water pollutants. Temperature boost by thermal discharge is shown in appendix 7 in the case of discharge from ground level.

In cases where heated water is discharged from submerged outfalls, the surface area of temperature boost is less than in cases of ground discharge. Dispersal of thermal discharge can also be analyzed by computer simulation.

#### 4.1.4 Dispersal of turbid water

A principal source of turbid water is dredging and dumping of dredged material. Typical patterns of turbid water generation in dredging and dumping are shown in appendix 8. Suspended solids (SS) in the water are usually used as an indicator of turbidity. Approximate quantities of SS generated by dredging and dumping of dredged materials are shown in appendix 8. Dredging of silt and clay by grab and bucket dredger generates considerable volume of SS compared to other methods. Water-tight grab bucket and low-pollution pump dredge have been developed to reduce SS generated in dredging. The rate of reduction is almost half in a case of low-pollution pump dredge and considerably low in a case of water-tight grab bucket. Dumping causes more turbidity than dredging, particularly in case of dumping from a hopper barge.

Figure A.8 in appendix 8 shows the relation between sediment particle size and the marginal velocity of flow suspending it in water. Large particles settle quickly while small ones remain in the water for a long period. Bottom sediments usually consist of particles in a certain range of sizes. Figure A.9 in appendix 8 is an example of particle size distribution where 36 per cent of sediment particles is smaller than 0.001 m/m. Joseph-Sendner's equation and Iwai-Inoue's equation are applicable to the dispersal of SS in cases where sediment particle sizes are very small and suspended for a long period. However, if particle sizes are large, sedimentation speed should be included in the calculation of dispersal of SS.

#### 4.1.5 Eutrophication

Figure 4.2 shows the mechanism of eutrophication, a process by which water becomes full of phosphates and other nutrients which encourage the growth of plankton and algae and kill other organisms through the shortage of dissolved oxygen. Major parameters concerned are the organic matter indicated by COD, BOD, dissolved oxygen (DO) and nutrient salts including nitrogen (N) and phosphorus (P) in water.

Computer models have been developed to simulate this process, which needs modelling of photosynthetic production of plankton, growth of plankton, sedimentation on the bottom, decomposition of organic material, and dissolution of nutrient salts in water.

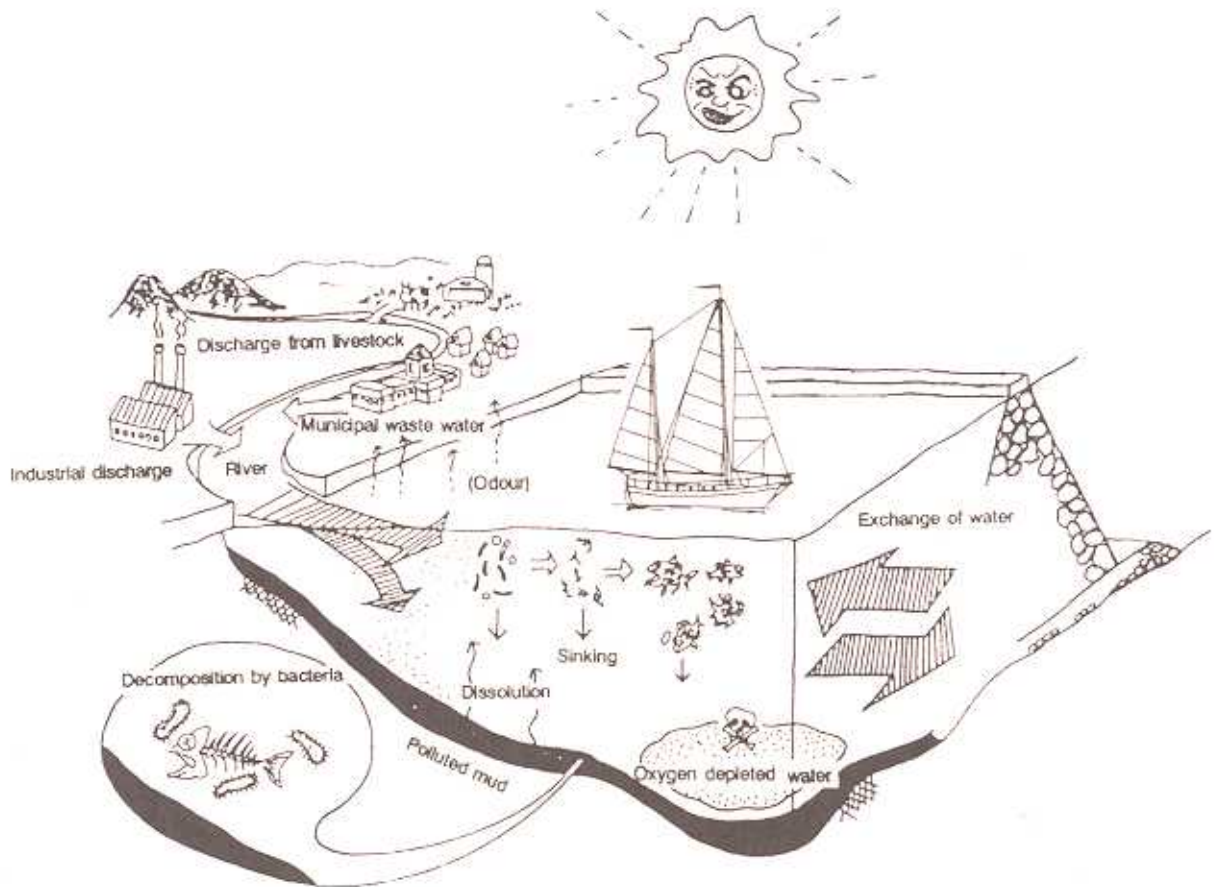

FIGURE 4.2 Mechanism of eutrophication

## 4.2 COASTAL HYDROLOGY

### 4.2.1 Survey of tides, currents and waves

Tides moves the water to high peaks usually twice each day, and twice a month to much higher peaks. Since the pattern of tidal change varies according to geographical locations, observation of tidal changes, preferably for a period of more than two weeks, is a requisite for analyzing the cycle and amplitude of tide. It is also possible to estimate tidal parameters from tide tables which are generally furnished for most operational ports.

A survey of current speed and direction is required to obtain input data for the simulation of tidal flow and dispersal of pollutants. Currents are altered by tidal changes and continuous observation is necessary for analyzing the cycle and amplitude of current components such as  $M_2$ , a component which periodically changes twice a day following the movement of the moon,  $S_2$ , a component which periodically changes twice a day following the movement of the sun, and other components. It is necessary to observe currents more than two weeks for analyzing their major components and fixed flow. When there is a difference in the flow of

upper and lower layers, multi-layer observation is necessary, including surface flow, usually two metres below the surface.

Wave observations are a prerequisite for reliable prediction of the highest wave and littoral drift. Two types of equipment are usually used for wave height observation: (a) an ultrasonic wave height measurer placed on the sea bottom; and (b) a buoy with acceleration gauges to calibrate wave height. The observation points should be 20 metres deep or more than five times the significant wave height targeted. The method of wave data transmission should be carefully selected from radio transmission, cable connection and periodical collection of recorded data at the observation points.

The period of wave observation should be long enough to include rough sea season, preferably over a period of more than two years. Data on high waves is important for the design of structures and long term wave data is important for analyzing wave energy which effects beach erosion or accretion. Surveys of the depth of sea bottom, littoral drifts, distribution of sand particle sizes are also necessary for the assessment of shoreline changes.

#### 4.2.2 Prediction of changes in coastal hydrology

Tides are usually unaffected by port construction, except in cases where an enormous amount of land reclamation takes place in a closed bay. Currents are altered by marine structures or land reclamation and their changes can be assessed by computer simulation models (subsection 4.1.2).

Wave prediction has been studied in connection with the design of marine structures and several methods have been established for the prediction of wave height, cycle, and irregularity. Typical methods are the SMB<sup>5</sup> method for wave prediction based on the duration and range of winds on the sea, the Bretschneider method for wave prediction in coastal water area, and the Wilson method for prediction of wave generation and transmission from typhoons or other sources of strong winds. Generated waves are transmitted toward the coast and their height and direction changed by refraction, diffraction and breaking.

Marine structures or land reclamation usually cause changes in currents and wave movements, which may result in changes in the shoreline configuration (e.g. beach erosion or accretion). Typical patterns of shoreline changes are shown in figure A.10 of appendix 9. Erosion and accretion take place alternately due to the change of onshore-offshore littoral transport and longshore littoral drifts. Once beach erosion takes place, groins or offshore breakwaters or a combination are required to trap sand and protect the beach from erosion.

Shore protection by groins is based on the idea that longshore littoral drifts are trapped by groins and small fragments of a beach form protective and stable pocket beaches. Breakwaters reduce onshore-offshore sand drift by breaking waves away from the shore. Breakwaters can trap sand in their sheltered area but may cause erosion somewhere outside of the shelter.

Sand bypassing or beach nourishment is another method to maintain a beach by supplying sand artificially to eroded sections. Sources of sand are usually accumulating sections of beach or dredging.

---

<sup>5</sup> SMB: Sverdrup-Munk-Bretschneider. A quasi-experimental — quasi-theoretical procedure to predict wave height developed by Sverdrup and Munk and revised by Bretschneider. (Reference 16)

### 4.3 MARINE AND COASTAL ECOLOGY

Surveys of aquatic biota are carried using a different method depending on each group of organisms. Sampling of aquatic organisms and their measurement is usually done by the methods listed in table 4.1

TABLE 4.1 Methods for sampling and measurement of aquatic organisms

Group of organisms	Sampling method	Measurement
Bacteria	Water sampling	Aerobic viable counting
Phytoplankton	Water sampling	Number off/cells
Zooplankton	Net sampling or water sampling	Weight of collected material and number of individuals
Seaweed	Quadrant sampling	Weight
Attached organisms	Quadrant sampling	Weight species and number of individuals
Benthic organisms	Bottom sediment sampling	Weight species and number of individuals
Fishery resources	Trial catch	Weight species and number of individuals

The biological characteristics of different eutrophication levels are summarized in appendix 10<sup>6</sup> with a short description of conditions of the water and bottom sediments. This table indicates likely changes of aquatic biota resulting from eutrophication of water. The levels of eutrophication are divided into four categories: (a) saprotrophic water (extremely polluted condition), (b) pertrophic water (severely polluted condition), (c) eutrophic water (slightly polluted condition), and (d) oligotrophic water (clean without pollution).

Mangroves and coral reefs are very sensitive ecological organisms which are intolerant to changes in the environment. Mangroves are easily affected by changes in current flow, salinity, oil film, and the deposit of silt. Coral reefs and their ecosystem are very fragile and sensitive to changes in water transparency, water temperature, salinity, eutrophication, siltation, oil film, and other similar pollution.

Adverse effects on marine and coastal ecology result from deterioration of water quality and contamination of bottom sediments. The relation between eutrophication levels and water quality indicators are also shown in appendix 10.

### 4.4 AIR QUALITY

The major pollutants generated by ports are dust, gases and offensive odours. The primary sources of dust are construction work, road traffic, and dry bulk cargo operations. Gas emissions are produced by ships, cargo handling equipment, and waterfront industries. Smoke, soot, fumes, vapours and odours are also generated by ships, cargo storage and handling, and waterfront industries. The range of dispersal of air pollutants varies with wind speed and the size of particles emitted. The study area surrounding the port should therefore be considerably wide in the case of air pollution.

<sup>6</sup> Prepared based on Eutrophication and Fishery Resources, Japanese Fishery Association, 1973

Odours usually originate from liquid cargo handling, bulk cargo storage and handling, fish processing, waste disposal sites, the deposit of dredged materials, and/or severely polluted water. Waterfront industries are also a major source of odours, particularly paper mills, meat and fish processing factories and cellophane and rayon industries.

#### 4.4.1 Survey on air pollution

Long term observation data of wind direction, wind speed, hours of sunshine, stability of the atmosphere and other meteorological characteristics are important as the base of an air pollution survey.  $\text{SO}_2$  and  $\text{NO}_2$  are major environmental indicators of air quality and observation of these indicators should be continued for more than one year to analyze seasonal changes of the atmosphere. Besides collecting data from such long term observations, field surveys of air pollution are useful as a complement to periodical surveys. Simple methods have been developed for air quality surveys such as detector tubes<sup>7</sup>, paper filters, film badges, and similar detectors.

Measurements with the detector tube are carried out to obtain the background concentration level. Diurnal changes in concentration levels mean that peak levels of  $\text{SO}_2$  are usually found in the daytime and peak levels of  $\text{NO}_2$  are found in the morning and evening. It is generally recommended that at least five observation sites be located in the area within a 10 km radius. Observation data of air quality indicators vary according to the time of day, week, month and year. One-hour and 24-hour averages are used for evaluation of  $\text{SO}_2$ ,  $\text{NO}_2$ , and SPM. One-hour and eight-hour averages are usually used for CO, and one-hour averages are used for oxidants (table 3.7 of page 26).

#### 4.4.2 Prediction of impacts on air quality

Dust dispersal is generally limited to a range of several hundred metres from the source. It has been reported, however, that dust particles with a diameter of 0.1 mm and a specific gravity of 3, emitted 20 metres above the ground into a wind moving 10 m/s, were dispersed over a distance of 2 km leeward from the point of emission.

##### 4.4.2.1 Gas emission and dispersion

Figure A.11 in appendix 11 shows the relationship between gas emissions and their concentration at ground level. The Y-axis is the distance from source and the X-axis is a function of gas concentration, which is calculated from  $XU/Q$ , where X is the maximum concentration at ground level, U is wind speed, and Q is the volume of gas discharged per second. Hourly maximum concentrations at ground level can be obtained from figure A.11 subject to inputs of wind speed and volume of gas emission. This prediction gives the possible hourly maximum level of pollutants at the ground leeward of the source and eight-hour and 24-hour averages are therefore much less than the predicted level.

The effective height of a chimney is the height above the ground where the plume of smoke from a factory or ship chimney becomes horizontal. This varies according to the speed of discharge from the chimney, the temperature of the emission, and wind speed. It can be estimated by visual observation of a similar chimney. Stability of the atmosphere refers to the

---

<sup>7</sup> A glass tube including a material reacting  $\text{CO}$ ,  $\text{CO}_2$ ,  $\text{SO}_2$ , or a particular gas and changing its colour in accordance with the quantity of pollutants.

Pasquill's stability class as shown in the table of appendix 11. In case of high stability, air pollutants are dispersed farther. However, a reversed temperature layer, which sometimes appears at a height of 100 - 200 metres in a stable atmosphere, interferes with the dispersal of airborne pollutants and causes severe concentration on the ground. This effect should be given special attention in predicting air pollution.

#### 4.4.2.2 Computer simulation

Several simulation models have been developed to predict the dispersal of air pollutants. These models usually calculate many patterns of dispersal corresponding to wind direction, wind speed, stability class of the atmosphere and the effective height of chimneys. They then sum up possible dispersal patterns according to the possibility of appearance of those factors. Basic formulas for these calculations are the Plume model, applicable to windy conditions, and the Puff model, suitable for calm conditions.

Sources of airborne pollutants are categorized as fixed sources such as factory chimneys and mobile sources such as vehicles and ships.  $\text{SO}_2$  is generated mainly by fixed sources and  $\text{NO}_2$  is from both fixed sources and mobile sources. Ships are a possible source of  $\text{SO}_2$  and  $\text{NO}_2$  emissions.

### 4.5 NOISE

#### 4.5.1 Survey of noise

Sources of noise are mainly road traffic, construction work and cargo handling equipment. Figure A.12 in appendix 12 shows noise levels of typical activities. The range of audible sounds is measured in decibels, which are calculated by measuring the sound pressure level. Decibels are calculated on a logarithmic scale. Double sound pressure is therefore measured as an increase of three decibel in the scale. The dBA is a refined scale from decibel to meet the hearing level of humans.

---

Noise level of typical activities (dBA)	
110—	klaxon at 2 m, riveting
100—	under a railway bridge
90—	inside of a noisy factory
80—	inside of a train, bell of telephone
70—	inside of a noisy office
60—	usual conversation, inside of a quiet car
50—	inside of a quiet office
40—	inside of a library, midnight in town
30—	whispering voice, midnight in suburban area
20—	rustling leaves

---

#### 4.5.2 Prediction of noise transmission

The noise level declines in proportion to the distance from the source. Due to a logarithmic scale, a decline of half the sound energy is measured as a decline of three dBA on the scale. In the case of a point source of noise, the noise level in dBA declines by 6 dBA at every double distance from the source. In case of a linear source of noise, such as a road, the noise level declines by 3 dBA at every double distance. Figure A.12 shows an example of noise reduction at certain distances. If the generated noise level was 100 dBA, the noise level at a distance of 20 m is 66 dBA in a case of point noise source and 82 dBA in a case of line source.

Obstacles between a noise source and the receiving point can reduce the noise level considerably. Trees, fences, houses and similar obstacles are effective barriers against noise. However, noise transmission in the upward direction is hardly affected. Noise refraction, diffraction and reflection are calculated by formulas of sound wave behaviour.

#### 4.6 ODOUR

Main sources of offensive odours are waterfront industries. Odours emitted from paper mills, meat and fish processing factories and cellophane and rayon factories can reach 10 km leeward from the source. Complaints against odours tend to be from the areas 2 - 3 km from the source. Odours from a foundry, petrochemical industry, or sewerage plant can reach at most 2 - 4 km leeward and complaints against odours tend to be from the area within 1 km from the source. In the case of other sources, complaints against odours usually come from within a distance of several hundred metres from the source. Prediction of dispersal ranges of odours can be done using the same methods used for air pollution.

#### 4.7 VISUAL POLLUTION

The aesthetic view of a coastal area sometimes has a significant impact on tourism in a region. The emergence of port facilities may degrade the natural scenery. A survey should include a study on the primary components of the view such as the sea, a river, the sky, mountains, plains, forests, a city, artificial structures, and the dominant colour of the proposed project area.

Angles of horizontal view, depression and elevation (figure A.13 in appendix 12) are indicators of the visual impact of the port area and port facilities. It is reported that the visual impact may be negligible if the angles are less than three degrees. Careful design of port facilities, including landmark of port, painting of port facilities, preservation of historical view of port, can create an favorable view and mitigate unpleasant images of the port. A montage photograph would be helpful to image the view of the port.

Excess lighting is another visual problem in ports. Since visual pollution is a difficult problem to mitigate, relocation of port facilities may be a possible means for coping with the problem.

## 5 METHODS FOR POLLUTION-LESS DREDGING AND RECLAMATION

### 5.1 DREDGING OF SLUDGE

Dredging is a major source of water pollution causing turbid water, resuspension of contaminated bottom sediments and other adverse effects, however, it is indispensable work for the construction of port structures, development of navigation channels and basin. Coping with requests for pollution-less dredging, special dredgers and equipment have been developed in the recent years. Typical methods for low pollution dredging are as follows:

#### 5.1.1 Air-pump dredger

The concept of air-pump dredging is shown in figure 5.1. An air-pump dredger consists of a drag head, a basal tank to suck the sludge and an air pump to discharge the sludge. To dredge, firstly, sink the system in the water till the drag head reach the middle of the sludge layer, then open the valve to release the air inside the basal tank, so that water pressure pushes the sludge into the basal tank. After sucking the sludge, compress the air in the tank and discharge the sludge outside through the pipe. Actual system has 2 - 3 basal tanks to ensure continuous dredging.

This method enables high density dredging with little disturbance to the sediments and without taking in much water together. In case of the dredging in the shallow water, the dredging performance of this method is not so high due to less water pressure to push up the sludge. To cope with this problem, a new type has a vacuum pump to reduce the air pressure in the basal tank and raise the capability of dredging in the shallow water.

FIGURE 5.1 Concept of the air-pump dredging<sup>8</sup>

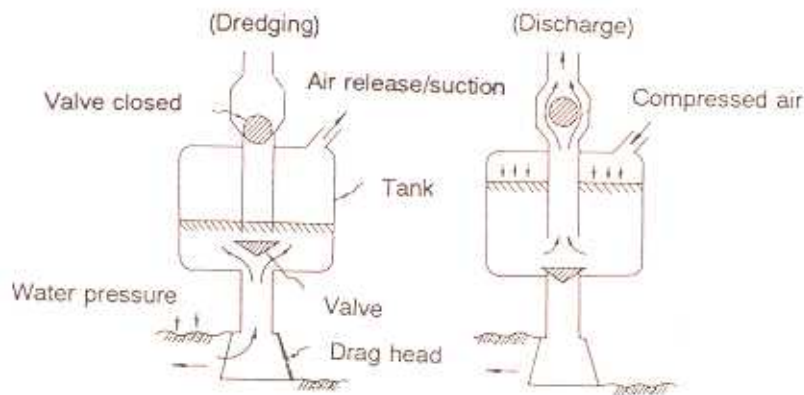

#### 5.1.2 Piston-pump dredging

The idea of piston-pump dredging is similar to the air-pump dredging (figure 5.2). A piston-pump system consists of a huge hydraulically-operated piston and a cylinder to intake sludge. Dredging procedure of this system is, firstly, to settle the intake in the sludge layer, secondly, move up the piston to suck the sludge, and then move down the piston to discharge the sludge inside of the cylinder.

<sup>8</sup> For example, "Dayasu Maru" Toyo-Construction Co., Ltd. listed in "Work Vessels", No.96, Japanese Work Vessel Association, 1974

Advantages and disadvantages of this method is also similar to the air-pump dredging. The both methods are not so effective to dredge a large volume of sediments but useful for dredging contaminated sediments without causing resuspension.

FIGURE 5.2 Piston dredging

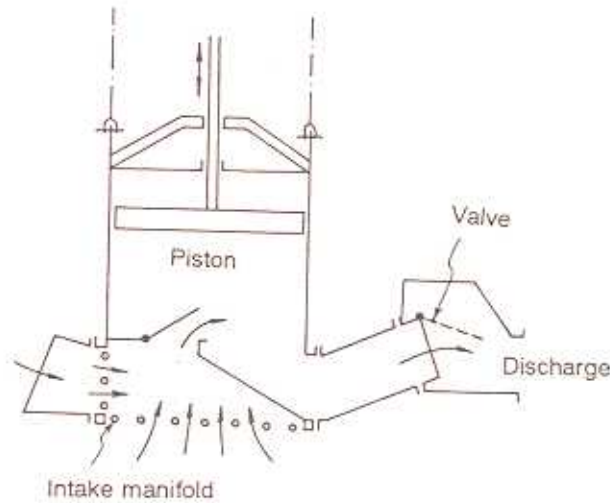

### 5.1.3 Low pollution pump dredging

Ordinary pump dredging usually disturbs bottom sediments by cutter blades and generates a considerable volume of SS in the water. With a view to reducing SS generation, several types of drag heads have been developed including cutter-less head. Figure 5.3 shows a special drag head equipped with a screw and full cover on the head. The drag head has only an opening in the front and moves ahead to take in the sludge. The sludge is stirred by screw and sucked in the drain pipe. The speed of rotation is changed according to the type of soil or sludge to enable high density dredging. The capacity of dredging is 100 - 500 m<sup>3</sup>/hour depending on the ability of pump.

FIGURE 5.3 Low pollution pump dredging

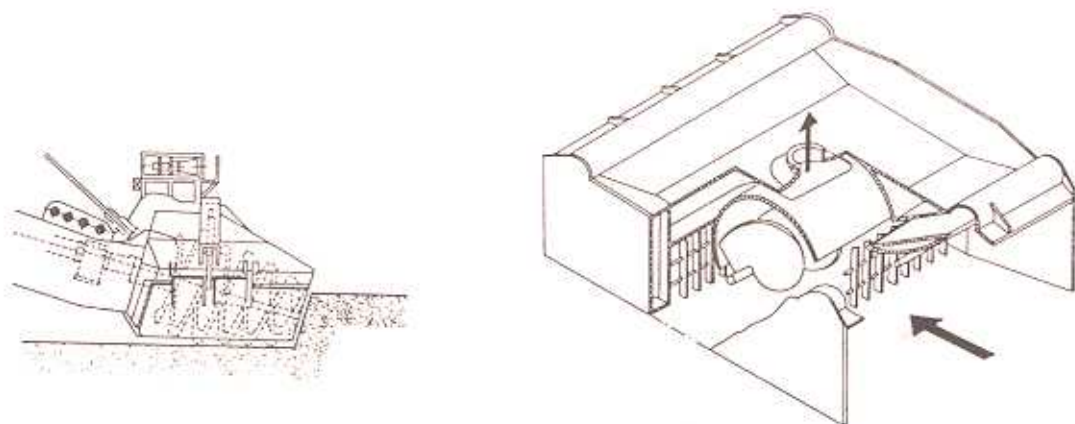

#### 5.1.4 Water-tight grab bucket<sup>9</sup>

Grab dredging usually generates more SS than other dredging methods (table in appendix 8), however, it is economical for small scale dredging and applicable to various dredging situations. For the use in sludge dredging, low pollution type grab bucket has been developed, which is designed to be water-tight and avoid scattering dredged sediments while pulling up in the water.

### 5.2 LAND RECLAMATION

#### 5.2.1 Settling pond

Land reclamation from the sea usually brings the problem of effluent of turbid water from pond in the landfill site. It is sometimes economical in the shallow water to reclaim the land by dumping landfill materials at the construction site without any revetment in the sea and build revetments after the emergence of the land. Though this method is economical and easy for construction, it generates a large volume of SS around the site, particularly when dredged materials but sand are discharged at the site. This method is not applicable to landfill by silt/clay nor to the sea area with high waves.

In view of the prevention of turbid water from land reclamation, revetments are usually built in advance of landfill. Structures of revetments are caisson, concrete block, sheet pile, cellular steel sheet pile, rubble mound, tetrapod-armoured rubble mound, and their combinations. Steel structures are water-tight but others need back-filling with water-tight sheet along the structure to prevent the leakage of landfill materials.

Settling pond plays an important role in reducing the effluent of turbid water. Figure A.13 shows various types of settling ponds to reduce SS in the effluent from the landfill site. The concept of designing a settling pond is (a) to locate far from the discharging point; (b) to be big enough to keep effluent water long and reduce the flow speed in the pond; (c) to overflow discharge water from the weir above the Low Water Level of the sea or drain through a pipe under the revetments. The use of coagulants encourages the settlement of fine materials but should be monitored at the outfall and nearby points in the sea. Filtration of discharge water through sand layer is also effective to reduce SS in the effluent.

#### 5.2.2 Waste disposal

Landfill is a possible means of waste disposal and ports in municipal areas are sometimes required to receive wastes in their land reclamation from the sea. Combustion of wastes is most effective for reducing the volume of wastes to be disposed of in landfills. In case of receiving ashes or harmful substances in land reclamation, revetments for landfill should be designed taking account of the water permeability of the structure.

Principal sources of wastes in ports are ships, cargo handling and storage, dredging, waterfront industries, and municipal activities. Adequate reception facilities for ship discharges should be provided at ports in accordance with international conventions (subsection 1.3.4) and national regulations. Dumping at sea is a means of disposing of some kinds of wastes, particularly dredged materials but should be done in accordance with the provision of the international dumping convention (appendix-4) and related national regulations.

---

<sup>9</sup> Development of water-tight grab bucket for sludge dredging, T. Matsumoto, "Work Vessels", No.98, Japan, 1975

## REFERENCES

1. Environmental Quality Act, 1974 (Act 127) and Subsidiary Legislation Made Thereunder, 1991. International Law Book Services (Malaysia)
2. Laws and Standards on Pollution Control in Thailand. 1986. Environmental Quality Standards Division, Office of the National Environmental Board, Thailand
3. Alcances, R. P., A. D. D. Supetran and M. B. Anderson, 1983. Environmental Impact Assessment Handbook (Philippines)
4. Keputusan Menterinegara Kependudukan dan Lingkungan Hidup, Nomor: KEP-02/MENKLH/1988. Tentang Pedoman Penetapan Baku Mutu Lingkungan. Sekretariat Menteri Negara, Kependudukan dan Lingkungan Hidup (Indonesia)
5. Hand-book on Environmental Impact Assessment. 1987. Central Environmental Authority (Sri Lanka)
6. Country Monograph: Korea. ESCAP 5-11 June 1984, Expert Meeting on the Integration of Environment into Development
7. Country Monograph: India. ESCAP 5-11 June 1984, Expert Meeting on the Integration of Environment into Development
8. Gangaiya, P. and D. Green, 1991. Monitoring of Trade Wastes Entering Suva and Lautoka Harbours (Fiji)
9. Environmental Guidelines for Planning in Hong Kong. 1990.
10. Quality of the Environment in Japan, 1989. Environment Agency, Government of Japan
11. Assessment of Urban Air Quality, The World Health Organization
12. Environmental Guidelines, 1988, The World Bank
13. Kankyo Roppou, 1990, Environment Agency, Government of Japan
14. Technical Manual of EIA of Port Development, 1983, Ministry of Transport, Japan
15. Dictionary of Ecology and the Environment, P.H. Collin, Peter Collin Publishing Ltd, 1988.
16. Shore Protection Manual, U.S. Army Coastal Engineering Research Center, Third edition 1977
17. Survey and prediction of pollution in the Omuta industrial harbour, S. Iwai and Y. Inoue, The 4th International Conference on Water Pollution Research, Prague, 1968
18. Hydraulic Formulas, Japan Civil Engineers Association, 1971
19. IAPH Guidelines on Port Safety and Environmental Protection, May 1989, The International Association of Ports and Harbors
20. Environmental Considerations for Port and Harbor Developments, John D. Davis, Scott MacKnight, IMO Staff, and Others, The World Bank, World Bank Technical Paper No. 126, 1990
21. Environmental Guidelines for Selected Infrastructure Projects, Office of the Environment, Asian Development Bank, 1990
22. How to Assess Environmental Impacts on Tropical Islands and Coastal Areas, Richard A. Carpenter and James E. Maragos, Environment and Policy Institute, East-West Center, Honolulu, October 1989
23. Environmental Guidelines for Coal Port Development, J.D. Wiebe, H.H. Webber, and others, Environment and Policy Institute, East-West Center, Honolulu, 1987

# APPENDIX 1 WORLD BANK CHECK LIST OF ENVIRONMENTAL IMPACTS FOR PORT AND HARBOR PROJECTS

(Source: Environmental Considerations for Port and Harbor Developments, World Bank Technical Report No.126, 1990)

## 1.0 WATER-RELATED IMPACTS

### 1.1 Impacts caused by dredging

- 1.1.1 Dispersal and settlement of resuspended sediments:  
Toxic, harmful substances in water column. Reduced available oxygen, sunlight penetration. Smothering bottom biota. Silt curtains to restrict dispersal. Relative impact of dredging methods. Knowledge of tidal and river flows.
- 1.1.2. Effects of blasting:  
Compression effects. Indirect effects on fisheries. Damage to shorezone and bulkhead structures.
- 1.1.3. Results of altered bathymetry:  
Influence on tidal and river flows. Altered salt wedge intrusion. Accelerated natural sediment deposition. Attraction of desirable or undesirable fisheries. Altered bottom biota.
- 1.1.4. Effects of changing shoreline configuration:  
Change in current patterns. Shorezone and beach erosion. Accelerated sediment deposition—shoaling.
- 1.1.5. Loss of bottom habitat, shellfisheries, fishery food resources:  
Exposed subsurface materials uncondusive to recolonization. Lost attachment potential for aquatic biota. Current pattern changes.
- 1.1.6. Altered groundwater flows:  
Salt water intrusion. Accelerated groundwater flow to estuary. Undermining of land-edge sediments. Saltwater intrusion to potable water supplies.

### 1.2. Impacts of dredged material disposal

- 1.2.1 Selection of appropriate disposal site:  
Disposal on land. Disposal in water. Desired character of disposal areas. Methods of dredging and dredged material transfer and related disposal impacts.
- 1.2.2. Unique Characteristics of Dredged Material
- 1.2.3. Disposal Methods
- 1.2.4. Disposal on land:  
Drainage. Loss of vegetation. Disposal of contaminants (toxins). Slumping. Revegetation. Aquifer contamination. Leaching of salt, etc.
- 1.2.5. Disposal in water — harbor/river or at sea:  
Dredged material transport and dumping methods. Loss of bottom biota. Biological recolonization rates. Potential or requirements for capping. Alteration of current patterns. Accelerated shoaling. Use of artificial islands.

- 1.3. Construction of piers, breakwaters and other waterside structures (new or extension/replacement of existing structures):
- 1.3.1. Filling or excavation covers/removes bottom biota and habitat: Shellfisheries. Fishery food resources lost or displaced.
  - 1.3.2. New habitats formed by structures (especially pilings and breakwaters): Desirable, undesirable species introduced.
  - 1.3.3. Filled structures (including breakwaters): Alter currents. Sediment deposition accelerated. Scouring increased. Change required in harbor maintenance dredging practices. New navigation routines. Protection of submerged pipelines.
  - 1.3.4. Disturbance from pile driving, other construction activities: Temporarily displace fisheries and other mobile marine/estuarine resources.
  - 1.3.5. Dispersal of suspended sediments: Smothering of bottom biota. Reduced light penetration. Displaced fisheries.
  - 1.3.6. Piling-supported structures — effects: Shade bottom. Change habitat. Attract desirable or undesirable species. Accelerated sediment deposition. Increased berth maintenance dredging. Increased nearby bottom scouring.
  - 1.3.7. Release of preservatives from installed wood structures: Prevent borer establishment. Contaminate fisheries. Release heavy metals to surrounding waters.
- 1.4. Alteration of harbor/port ship traffic patterns:
- 1.4.1. Changes in channel, anchorage and turning basin locations: Dredging and dredge material disposal, Increased frequency of maintenance dredging. (See Section 1.1).
  - 1.4.2. Relocation of navigation markers, moorings: Assurance of location precision. Designation of channels for arrival/departure traffic.
  - 1.4.3. Addition of new channels, anchorages, turning basins requiring improvement dredging. (See Section 1.1.).
  - 1.4.4. Improved procedures for vessel traffic control (VTS) systems. Requirements for collision avoidance systems. Radar. Shorebased radar reflectors. LORAN-C, GPS, DECCA, etc. Requirements for ships using facility. Pilotage.
  - 1.4.5. Increased provision for vessel handling and servicing: Additional tugs, lighters, service vessels. Vessel repair facilities. Drydocks. Graving Docks.
- 1.5. Ship discharges — oily ballast, bilge water, sewage
- 1.5.1. Promulgation of regulations controlling cleaning procedures, limitations on release of cargo and machinery space residues. Discharge limitations — examples cited. Need for facilities to receive waste from ships. Means of storage and ultimate disposal of residual wastes.

- 1.5.2. Environmental sensitivity to discharges from ships. Importance to fishery resources. General water quality of rivers, bays, harbors. Effects if requirements not imposed or regulations not enforced.
  - 1.5.3. Development of shore facilities for receiving ship generated sewage and garbage waste. Sanitary treatment facilities — connection to special or municipal systems. Transfer and pumping facilities. Ultimate disposal of these wastes.
  - 1.5.4. Effects of antifouling paints:  
Relation to ships in dock. Ships in repair. Repair and maintenance practices allowed, not allowed. Effects on biota in water, fisheries. types of antifoulants — tributyl-tin, copper based. Vessels berthed in shallow water.
- 1.6. Spills: detection and clean-up of spills
- 1.6.1. Type of Spills:  
Oils. Lubricants. Hydraulic oils. Fuels. Liquid and solid chemicals. Behavior in water. Likely causes of spills. Frequent spill sources — equipment, faulty practices.
  - 1.6.2. Resources at risk:  
Identify areas subject to spills. Aquatic resources most likely in jeopardy: Spill-prone areas. Shellfish resources. Fishery resources. Aquaculture operations.
  - 1.6.3. Spill clean-up measures:  
Regulations. Clean-up equipment available, to be added. Spill retention measure — equipment, emergency procedures. Spill detection routines.
  - 1.6.4. Dry cargo releases:  
Fugitive emissions. Dust control. Enclosed loading and unloading systems. Smoke density and effects.
  - 1.6.5. See also hazardous cargoes
- 1.7. Waterfront industry discharges — sanitary and non-sanitary
- 1.7.1. Sanitary wastes:  
sources. Volumes. Special contaminants. Produced by project. Not produced by project.
  - 1.7.1.1. Sanitary treatment facilities:  
Existing. Planned. Proposed. Capacity of each. Locations. Discharge water quality — actual and designed. Ability to handle shipping.
  - 1.7.2. Non-sanitary wastes.  
Sources. Volumes. Important contaminants (toxins). Produced by project. Not produced by project.
  - 1.7.2.1. Discharge/treatment procedures.  
Capacities. Piping systems. How discharged/treated. Discharge limitations — imposed, actual. Residuals — actual, designed.
  - 1.7.2.2. Discharges reaching harbor/river waters.  
Behavior in water, sediments. Dispersion. Settling tendencies. Chemical reactions in water. Effects on biota, aquaculture.
  - 1.7.2.3. Possible needed retention and treatment systems:

Feasibility. Costs. Cost effectiveness. Possible resource recovery.

- 1.7.2.4. Non-sanitary spillage from non-ship related activities:  
Types of spills. Frequency. Volumes. How handled. Retention/recovery systems. Emergency routines.
- 1.7.2.5. Non-sanitary discharges/releases from ship repair:  
Paints. Paint compounds. Other chemicals — hydraulic fluids, etc. Antifoulants. Ship refuse.
- 1.7.3. Heated process water discharges:  
Electricity generation. Industrial processes. LNG condensation. Port/harbor hydrography. Tidal prisms. Effects of heated water on biota. Use in aquaculture. Definition of mixing zones. Potential for blocking fish passage.
- 1.7.4. Brine from desalinization plants:  
Efficiency of mixing. Salinity of receiving waters. Port/harbor hydrography. Tidal prisms. Efficiency of diffusion. Effects on biota, aquaculture.

## 2.0. LAND-RELATED IMPACTS

### 2.1. Excavation for fill (rock or aggregate):

- 2.1.1. Loss of upland-vegetation:  
Cropland. Windbreaks. Degradation of Upland appearance. Soil cover. Prevention of erosion. Mudslide potential. Flooding potential.
- 2.1.2. Damage from shore sand/gravel excavation:  
Coastal dunes. Destabilization of shoreline. Acceleration of inland dune migration. Increased sandstorm frequency.
- 2.1.3. Dust (fugitive emissions):  
From drilling. Truck traffic and construction equipment. Wind velocity, direction. Dust control and suppression measures.
- 2.1.4. Blasting and Its Effects:  
Control of debris. Danger from inadequate blast zone coverage. Work area restrictions. Safety regulations. Damage to aquifers. Noise. Dust. Threats to livestock.
- 2.1.5. Requirements for land restoration:  
Pre-construction assessment of land appearance. Aesthetics. Restoration techniques. Landscaping. Constructive use of restored land cover. Need for selection criteria for filled lands to avoid nearshore storm surge inundation.

### 2.2. Wetland damage and filling:

Discussion of needs. Purpose.

- 2.2.1. Ecological value of wetlands:  
Agricultural use. Waterfowl use. Use by domestic animals. Use by other fauna. Unique vegetation. Food source for aquatic or non-aquatic biota. Irrigation water source.
- 2.2.2. Flood plain functions:  
River flooding retention capacity. Tidal flooding capacity. Water retention intervals. Flooding related to irrigation source capacity.

- 2.2.3. Watershed/groundwater source quality:  
Groundwater recharge function. Groundwater discharge function. Relation to used aquifer(s). Source of surface streams. Flow rates.
- 2.2.4. Runoff (longterm) from developed areas (including ports and harbor facilities).  
Receiving function for natural surface runoff. Receiving area for developed area runoff — municipal, industrial. Existing contamination input. Contaminant buildup rates. Present background contaminant levels.
- 2.3. Loss of usable uplands to expanding waterfront/industrial areas:
  - 2.3.1. Types of land areas likely lost to industrial or waterfront use. Farmlands. Residential areas. Market centers. Commercial areas.
  - 2.3.2. Extent to which relocation compensates for lost land use:  
Extent of involuntary re-settlement. Residential relocation. Replacement farmlands. Other replacement/relocation needs. Requirements for associated needs-water, sewer, electricity, roads, fuel, etc.
- 2.4. Noise from ports and harborside industry:
  - 2.4.1. Planning for possible strategic location of noise sources. Determination of existing background. Prediction of noise addition. Buffer zones. Designation of special high noise areas. Control of construction noise. Suppression, muffled equipment.
- 2.5. Effects of dust and other airborne emissions:
  - 2.5.1. Dust and other non-combustion particulates:  
Sources — industrial, construction. Raw material storage. Intensity. Periodicity. Wind rose indication of most likely affected areas. Smothering of shorezones and coral reefs. Screening by vegetation, windbreaks.
  - 2.5.2. Smoke and other combustion products:  
Sources — ships, traffic, industry. Emission composition (toxins). Control equipment in place, required. Regulatory requirements/limits. Wind rose data to indicate probable impact areas.
- 2.6. Traffic burden projections:
  - 2.6.1. Existing traffic load:  
Roadway network. Traffic load. Accident data. Types of traffic. Periodicity. Weight loading. Pavement damage. Axle load limits, etc.
  - 2.6.2. Projected traffic increases:  
Needed roadway additions/improvements. Important routes. Traffic loads — commercial, construction. Destinations. Needs for traffic control.
- 2.7. Handling and disposal of solid shore generated wastes:
  - 2.7.1. Important sources:  
Ships. Waterfront industrial areas. Residential areas.
  - 2.7.2. Means of transport/transfer:  
Ship-to-shore. Onshore. Vehicle types. Compactors. Intermediate collecting sites.
  - 2.7.3. Disposal methods:

2.7.3.1. Incineration:  
Proper siting. Possible recycling. Possible emissions (toxins, etc., — see Section 2.5.2.). Disposal of residual ash. Energy generation.

2.7.3.2. Landfills:  
Proper siting. Aquifer/groundwater protection. Need to protect shoreline from erosion, etc. Site preparation. Surface water control — runoff. Proximity to water supplies — surface and subsurface, farmlands. Materials deposited, including incineration ash. Avoid placement in nearshore areas subject to erosion. Use of filter cloths and silt fences.

## 2.8. Runoff from raw material storage:

2.8.1. Nature of materials:  
Salt. Sulfur. Metal ores. Refined concentrates. Potential for toxic releases.

2.8.2. Exposure effects:  
Typical storage conditions. Locations. Storage time. Weathering effects — rain, wind, sun. Health menace to workforce. Need for containment of runoff. Protection of groundwater. Need for enclosure, cover. Grain spillage — measures to prevent/control.

## 2.9. Waterfront drainage:

2.9.1. Drainage components:  
Contaminants (toxins). Volumes. Oils (hydraulic, etc.).

2.9.2. Drainage collection systems:  
Extent of existing systems. Pavement "watershed." Collection conduits. Means of disposal. Cleaning/skimming for oil separation.

2.9.3. Biological effects of disposal:  
Effects if directed to rivers, streams, wetlands. Effects if directed to harbor, bay. Effects on fisheries, aquaculture.

## 2.10. Industrial liquid wastes not discharged to harbor: Possible hazardous/toxic.

2.10.1. Storage and handling methods:  
Storage sites. Containment structures and materials. Proper placement and management. De-toxification options. Recycling possibilities.

## 2.11. Visual impacts — location. Aesthetics: Structure. Painting. Attempts to blend with surroundings.

# 3.0. AIR-RELATED IMPACTS

## 3.1. Important background information:

3.1.1. Meteorological Data:  
Prevailing winds. Seasonal weather patterns. Storm tracks, frequency and severity. Rainfall records. Wind rose data. Identify probable downwind impact areas.

3.1.2. Background data on prevalence of present airborne substances:  
Individual carrying/travel capacities. Chemical reactions while airborne. Chemical reactions with water.

- 3.1.3. Identify sensitive areas:  
Farmlands. Forests. Grazing lands. Residential areas. Water reservoirs.

3.2. Fugitive emissions (see also Section 2.5)

- 3.2.1. Sources and control measures:  
Dust — types, sources. Wetting and other control measures. Enclosed conveyor loading systems for ships loading dry cargo. Construction activities.

3.3. Gases, smoke, and fumes

- 3.3.1. Sources, components, controls:  
Industrial contributions. Ships. Residential background. Vehicle emissions. Background from other areas. Control measures. Regulatory limits. Health-threatening toxins. Threats to agriculture and fisheries.

## 4.0. HAZARDOUS MATERIALS/CARGOES

- 4.1. Categories — gases, liquids, solids:  
Examples. Hazardous rating. Condition — required for industrial processes, waste products, finished products.

- 4.1.1. Key considerations:  
Identity of materials. Volumes/quantities usually on hand. How stored. Location of storage areas — segregation. Shipping and handling procedures. Bunding and other containment precautions associated with bulk storage and tank farms. Disposal of any hazardous wastes generated.

## 5.0. SOCIO-CULTURAL IMPACTS

Tribal, cultural, ethnic, historical, religious aspects likely impacted by changes, including consequences of modernization and industrialization. Landscape factors integrated with culture, traditions, etc. How affected. Possible measures easing transition. Preserving traditions with minimum loss and disturbance. Removal of graveyards, etc.

## 6.0. REVIEW OF EXISTING AND PROPOSED REGULATIONS AFFECTING THE PROPOSED PORT OR HARBOR DEVELOPMENT AND ITS CONSTRUCTION

Environmental. Safety. Financial. Criminal. Export-import. Labor. Foreign consultant/labor use. Laws, regulations tied to socio-religious traditions, etc.

## 7.0. NEED FOR CONSTRUCTION OR FACILITY OPERATION ENVIRONMENTAL MONITORING

Basis — Most Sensitive Environmental Considerations. Program Planning. Management and Regulation Enforcement, Program termination.

(Source: Environmental Guidelines for Selected Infrastructure Projects, Office of Environment, ADB, 1990)

Actions Affecting Environmental Resources and Values	Damages to Environment	Recommended Feasible Protection Measures
<p>A. Actions Affecting Coastal Marine Ecology</p> <ol style="list-style-type: none"> <li>1. Location of harbor in fisheries reproduction</li> <li>2. Location of harbor in fisheries capture zones</li> <li>3. Disposal of dredging spoils into fisheries reproduction zones</li> <li>4. Disposal of dredging spoils into coral beds</li> <li>5. Oil spills/Leakage within harbor which escape harbor area</li> <li>6. Oil spills from tankers on way to and from harbor</li> </ol>	<ol style="list-style-type: none"> <li>1. Loss of fisheries reproduction</li> <li>2. Displacement of fishermen families</li> <li>3. Loss of fisheries reproduction</li> <li>4. Loss of fragile/precious marine ecology</li> <li>5. Damage to marine ecology (fisheries/corals)</li> <li>6. Damage to marine ecology (fisheries/corals)</li> </ol>	<ol style="list-style-type: none"> <li>1. Consider relocation of harbor site</li> <li>2. Relocation of fishing zones</li> <li>3. Proper spoils disposal</li> <li>4. proper spoils disposal</li> <li>5. Improved routine and emergency control of oil leakage/spills</li> <li>6. Improved routine and emergency control of oil leakage/spills</li> </ol>
<p>B. Actions Affecting Recreational/Resort/Beach Areas along Coastal Zone</p> <ol style="list-style-type: none"> <li>1. Location of harbor too close to recreational areas</li> <li>2. Escape of liquid and solid wastes from harbor area, especially floatables</li> <li>3. Air pollutant emissions from harbor ships/facilities</li> <li>4. Disposal of dredging spoils which reach along shoreline</li> <li>5. Oil spills/leakage within harbor which escape harbor area</li> <li>6. Oil spills from tankers on way to and from harbor</li> </ol>	<p>B. Depreciation of Recreation Areas by:</p> <ol style="list-style-type: none"> <li>1. Visible turbidity or discoloring of beach waters</li> <li>2. Silt deposition along shoreline</li> <li>3. Visible floatable wastes</li> <li>4. Waste deposition along shoreline</li> <li>5. Oil firms on beach waters and shoreline</li> <li>6. Contamination of beach waters (pathogenic hazard)</li> </ol>	<ol style="list-style-type: none"> <li>1. Consider relocation of port or of resort</li> <li>2. Extraordinary attention to liquid/solid waste management</li> <li>3. Extraordinary attention to air pollution control</li> <li>4. Proper spoils disposal</li> <li>5. Improved spill/leakage control and improved emergency oil spill cleanup</li> <li>6. Improved emergency oil spill cleanup</li> </ol>

(continued....)

Actions Affecting Environmental Resources and Values	Damages to Environment	Recommended Feasible Protection Measures
<p>C. Actions Causing Unacceptable Sanitation Conditions in Harbor Area</p> <ol style="list-style-type: none"> <li>1. Inadequate provision of water supply to port facilities and ships</li> <li>2. Inadequate management of waste emissions from port facilities               <ol style="list-style-type: none"> <li>(a) liquid sanitary and industrial wastes</li> <li>(b) solid sanitary and industrial waste</li> <li>(c) gaseous emission from shore industries</li> </ol> </li> <li>3. Inadequate management of wastes from ships               <ol style="list-style-type: none"> <li>(a) liquid wastes, especially floatables including bilge waters</li> <li>(b) solid wastes, especially floatables, including garbage</li> </ol> </li> <li>4. Escape of oils within harbor</li> </ol>	<p>C. Unsanitary Harbor Environment, including:</p> <ol style="list-style-type: none"> <li>(a) unacceptable environmental activities</li> <li>(b) health hazards to port and ship workers</li> <li>(c) destruction of harbor fishery/ecology</li> <li>(d) hazards for pollution of coastal areas by escape of wastes from harbor</li> </ol> <ol style="list-style-type: none"> <li>3. Similar to A(1) (2) (3) (4) above</li> <li>4. Similar to A(1) (3) (4) above</li> </ol>	<ol style="list-style-type: none"> <li>1. Extraordinary attention to water supply</li> <li>2. Extraordinary attention to waste management from shore facilities</li> <li>3. Extraordinary attention to management from ships</li> <li>4. Improved routine and emergency controls of oil leakage and spills</li> </ol>
<p>D. Handling of Hazardous Cargoes Within Harbor especially</p> <ol style="list-style-type: none"> <li>1. Dust emissions (for example handling of coral and cassava dusts)</li> <li>2. Hazardous materials (inflammables, explosives, toxic substances)</li> </ol>	<p>D. Similar to A(1) (2) (3) (4)</p> <ol style="list-style-type: none"> <li>1. Air pollution and explosion hazards</li> <li>2. Health and safety of workers and nearby residents</li> </ol>	<p>D. Extra Careful Attention in Design/Operations</p> <ol style="list-style-type: none"> <li>1. Proper air pollution control</li> <li>2. Proper control of hazardous materials</li> </ol>
<p>E. Handling of rials to and from Harbor</p> <ol style="list-style-type: none"> <li>1. Traffic congestion</li> <li>2. Hazardous material spills (inflammables, explosives, toxic)</li> </ol>	<ol style="list-style-type: none"> <li>1. Air pollution and explosion hazards</li> <li>2. Health and safety of workers and nearby residents</li> </ol>	<ol style="list-style-type: none"> <li>1. Proper air pollution control</li> <li>2. Proper control of hazardous materials</li> </ol>

(continued...)

Actions Affecting Environmental Resources and Values	Damages to Environment	Recommended Feasible Protection Measures
<p>F. Actions Affecting Local Socioeconomics</p> <ol style="list-style-type: none"> <li>1. Inadequate housing for new population</li> <li>2. Inadequate health precautions during construction (especially malaria)               <ol style="list-style-type: none"> <li>(a) communicable disease hazards from imported workers/carriers</li> <li>(b) inadequate water supply and sanitation for workers</li> </ol> </li> <li>3. Changes in land use patterns:               <ol style="list-style-type: none"> <li>(a) displacement of agriculture</li> <li>(b) displacement of villages</li> </ol> </li> <li>4. Excessive noise from harbor operations</li> </ol>	<ol style="list-style-type: none"> <li>1. Hazards for creating slums</li> <li>2. Communicable disease hazards               <ol style="list-style-type: none"> <li>(a) proper precautions during construction</li> <li>(b) provision of adequate facilities</li> </ol> </li> <li>3.               <ol style="list-style-type: none"> <li>(a) loss of agricultural values</li> <li>(b) displacement of villages</li> </ol> </li> <li>4. Health of harbor workers and nearby residents</li> </ol>	<ol style="list-style-type: none"> <li>1. Planning to prevent slum problems</li> <li>2. Proper planning of construction worker facilities               <ol style="list-style-type: none"> <li>(a) spraying of worker's camp for anopheline mosquito control</li> <li>(b) provision of adequate facilities</li> </ol> </li> <li>3.               <ol style="list-style-type: none"> <li>(a) appropriate resettlement</li> <li>(b) - ditto -</li> </ol> </li> <li>4. Adequate noise control</li> </ol>
<p>G. Actions Affecting Terrestrial Ecology</p> <ol style="list-style-type: none"> <li>1. Adverse impacts on local forest</li> <li>2. Adverse effects on wildlife from loss in forest habitat</li> <li>3. Adverse effects on estuarine lagoons (fisheries, wildlife)</li> </ol>	<ol style="list-style-type: none"> <li>1. Similar to A(1) to A(6) above</li> <li>2. - ditto -</li> <li>3. - ditto -</li> </ol>	<ol style="list-style-type: none"> <li>1. Similar to A(1) to A(6) above</li> <li>2. - ditto -</li> <li>3. - ditto -</li> </ol>
<p>H. Actions Caused by Changes in Coastal Hydrology</p> <ol style="list-style-type: none"> <li>1. Deposition along nearby coastal areas</li> <li>2. Erosion along nearby coastal areas</li> </ol>	<p>H. Physical Damage to Coastal Facilities/Ecology</p> <ol style="list-style-type: none"> <li>1. Damage to Resources</li> <li>2. - ditto -</li> </ol>	<p>H. Careful Project Design with Respect to Hydrology, plus protection facilities</p> <ol style="list-style-type: none"> <li>1. Proper engineering to avoid problems</li> <li>2. - ditto -</li> </ol>
<p>I. Actions Affecting Precious Historical/Cultural/Religious Monuments/Sites</p> <ol style="list-style-type: none"> <li>1. By displacement on submergence</li> <li>2. By alternations in coastal zone hydrology/ shoreline</li> </ol>	<p>I. Loss or Damage to Resources</p>	<p>I. Relocation or Protection Measures</p>
<p>J. Hazards from Access Roads/Traffic Leaving Harbor</p>	<p>J. Collision/Spill Hazards to Ships</p>	<p>J. Proper Design for Harbor Access</p>
<p>K. Navigation Hazards from Ships Entering or Leaving Harbor</p>		

## APPENDIX 3 IAPH CHECK LIST OF ENVIRONMENTAL IMPACTS OF PORTS AND COASTAL AREA DEVELOPMENTS

(Source: IAPH Guidelines for Environmental Planning and Management in Ports and Coastal Area Developments 1989)

### 1. Climate & Air Quality

#### Wind directions and speed

Will the project (structure and area) modify the local wind behavior, e.g. channelling of wind, obstruction, etc? Will the project be placed in a "high risk" area?

#### Precipitation/humidity

Will the project have an impact upon the local precipitation/humidity pattern? Will the project be sited in a "high risk" area?

#### Temperature

Will the project have an impact upon the local temperature pattern?

#### Air quality

Will the project generate and disperse atmospheric pollutants?  
Will the project generate any intense odours?

### 2. Water

#### Hydrological balance

Will the project alter the hydrological balance?

#### Groundwater regime

Will the project affect the groundwater regime, e.g. in terms of quality, quantity, depth/gradient of water table and direction of flow? Will alterations to water table depth alter structural qualities of soil? Will dewatering methods be necessary to undertake excavations?

#### Drainage/channel pattern

Will the project impede the natural drainage pattern and/or induce alteration of channel form?

#### Sedimentation

Will the project induce a major sediment influx into area water bodies?

#### Flooding

Will there be risk to life and materials due to flooding?

#### Water quality

Does potable water supply meet established standards--WHO, etc? Will receiving waters meet established standards? Will waters be adequately accommodated and treated? Will groundwater suffer contamination by surface seepage, intrusion of saline or polluted water?

#### Surface waters

Will the project impair existing surface waters through filling, dredging, water extraction or discharge; waste discharge or other detrimental practices? Will recreation or aesthetic values be endangered? Will the project affect dry weather flow characteristics?

### 3. Geology

#### Unique/special features

Will features be affected by project activities?

#### Tectonic/seismic activity and volcanic activity

Is there risk of damage or loss resulting from tectonic/seismic activity and/or volcanic activity?

#### Mineral resources

Are there mineral resources of potential value close to the project?

#### Physical/Chemical weathering

Will there be an increase in rock decomposition/degradation as a result of the project?

#### Landslide

Are there potential dangers related to slope failures or falling rock.

#### Subsidence

Is there risk of major ground subsidence associated with the project?

### 4. Soil

#### Erosion (wind and water)

Will there be a substantial loss of soil due to construction or operational practices?

#### Slope stability

Will there be a risk of losses due to instability?

#### Liquefaction

Will project cause or be exposed to liquefaction of soils in slopes or foundations?

#### Bearing capacity

Will there be risk to life or structures because of sudden failure?

#### Settlement/heave

Is there risk of damage to structure or services?

#### Earthworks

Will there be an alteration to existing conditions, e.g. water regime or topography, or the need for landscaping?

#### Soil structure

Will the project modify the properties of impacted soils?

### 5. Ecology

#### Species checklists

Are there rare/endangered species which require protection? Are there species which are particularly susceptible to human activities? Would the loss of certain plant species deny food or habitat to wildlife species?

#### Plant communities

Are there any unusual populations/ communities that may be of scientific value? Are there natural populations/communities that are particularly susceptible to human activities?

#### Diversity (species & spatial)

Does the diversity (species & spatial) of any community render it susceptible to human activities?

#### Productivity

Will project activities impair natural productivity?

Biogeochemical/nutrient cycling

Will project activities disrupt nutrient materials flow, e.g. selective concentration/dilution of substances?

## 6. Environmentally Sensitive Areas

Prime agricultural land

Will the project be located on or near prime agricultural land?

Forestry land

Will the project be located on or near forestry land?

Wetlands/estuarine and coastal zones

Will the project impair existing wetlands/coastal zones/shorelines through filling, dredging, waste discharges or other detrimental practices? Impact on recreation?

Landfills, solid/toxic waste disposal sites

Will the project perturb abandoned, existing or planned landfills, solid/toxic waste disposal sites?

## 7. Land Use and Land Capability

Land use

Will the project conflict with existing or proposed land use?

Land capability

Will the project degrade land capability types?

## 8. Noise & Vibrations

Internal noise

Will the internal noise levels present a potential risk to the hearing of workers? Will the safe operation of the project be affected?

External noise

Will the project create noise levels which will cause annoyance, discomfort to nearby properties?

Vibration

Will the project cause damage to structures (natural and man-made) due to vibration? Will the vibration levels within the plant be such that there is a risk to employee safety.

## 9. Visual Quality

Visual content and coherence

Will the content of the scene perceived by the residents of the surrounding area be adversely affected by the project? Will the coherence of the surrounding area be impaired by the project?

## 10. Archaeological, Historic & Cultural Elements

Archaeological structures and sites

Will the project conflict with structures and sites of archaeological interest and value? Will existing and desirable future patterns of access be disrupted?

Historic/cultural structures, sites and areas

Will the project conflict with structures, sites and areas of historic/cultural interest and value? Will existing and desirable future patterns of access be disrupted?

## APPENDIX 4 LONDON DUMPING CONVENTION

### CONVENTION ON THE PREVENTION OF MARINE POLLUTION BY DUMPING OF WASTES AND OTHER MATTER<sup>10</sup>

Articles I - II omitted

#### Article III

For the purposes of this Convention:

1. (a) "Dump" means:
    - (i) any deliberate disposal at sea of wastes or other matter from vessels, aircraft, platforms or other man-made structures at sea;
    - (ii) any deliberate disposal at sea of vessels, aircraft, platforms or other man-made structures at sea.
  - (b) "Dumping" does not include:
    - (i) the disposal at sea of wastes or other matter incidental to, or derived from the normal operations of vessels, aircraft, platforms, or other man-made structures at sea and their equipment, other than wastes or other matter transported by or to vessels, aircraft, platforms or other man-made structures at sea, operating for the purpose of disposal of such matter or derived from the treatment of such wastes or other matter on such vessels, aircraft, platforms or structures;
    - (ii) placement of matter for a purpose other than the mere disposal thereof, provided that such placement is not contrary to the aims of this Convention.
  - (c) The disposal of wastes or other matter directly arising from, or related to the exploration, exploitation and associated off-shore processing of sea-bed mineral resources will not be covered by the provisions of this Convention.
2. "Vessels and aircraft" means waterborne or airborne craft of any type whatsoever. This expression includes air cushioned craft and floating craft, whether self-propelled or not.
  3. "Sea" means all marine waters other than the internal waters of States.
  4. "Wastes or other matter" means material and substance of any kind, form or description.
  5. "Special permit" means permission granted specifically on application in advance and accordance with Annex II and Annex III.
  6. "General permit" means permission granted in advance and in accordance with Annex III.
  7. "The Organization" means the Organization designated by the Contracting Parties in accordance with Article XI(2).

#### Article IV

1. In accordance with the provisions of this Convention Contracting Parties shall prohibit the dumping of any wastes or other matter in whatever form or condition except as otherwise specified below:
  - (a) the dumping of wastes or other matter listed in Annex I is prohibited;
  - (b) the dumping of wastes or other matter listed in Annex II requires a prior special permit;

---

<sup>10</sup> Adopted by the Inter-governmental Conference on the Convention on the Dumping of Wastes at Sea, London, October 30 to November 13, 1972.

- (c) the dumping of all other wastes or matter requires a prior general permit.
2. Any permit shall be issued only after careful consideration of all the factors set forth in Annex III, including prior studies of the characteristics of the dumping site, as set forth in Sections B and C of that Annex.
  3. No provision of this Convention is to be interpreted as preventing a Contracting Party from prohibiting, insofar as that Party is concerned, the dumping of wastes or other matter not mentioned in Annex I. That Party shall notify such measures to the Organization.

#### Article V

1. The provision of Article IV shall not apply when it is necessary to secure the safety of human life or of vessels, aircraft, platforms or other man-made structures at sea in cases of *force majeure* caused by stress of weather, or in any case which constitutes a danger to human life or a real threat to vessels, aircraft, platforms or other man-made structures at sea, if dumping appears to be the only way of averting the threat and if there is every probability that the damage consequent upon such dumping will be less than would otherwise occur. Such dumping shall be so conducted as to minimize the likelihood of damage to human or marine life and shall be reported forthwith to the Organization.
2. A Contracting Party may issue a special permit as an exception to Article IV(1)(a), in emergencies, posing unacceptable risk relating to human health and admitting no other feasible solution. Before doing so the Party shall consult any other country or countries that are likely to be affected and the Organization which, after consulting other Parties, and international organizations as appropriate, shall, in accordance with Article XIV promptly recommend to the Party the most appropriate procedures to adopt. The Party shall follow these recommendations to the maximum extent feasible consistent with the time within which action must be taken and with the general obligation to avoid damage to the marine environment and shall inform the Organization of the action it takes. The Parties pledge themselves to assist one another in such situations.
3. Any Contracting Party may waive its rights under paragraph (2) at the time of, or subsequent to ratification of, or accession to this Convention.

#### Article VI

1. Each Contracting Party shall designate an appropriate authority or authorities to:
  - (a) issue special permits which shall be required prior to, and for, the dumping of matter listed in Annex II and in the circumstances provided for in Article V(2).
  - (b) issue general permits which shall be required prior to, and for, the dumping of all other matter;
  - (c) keep records of the nature and quantities of all matter permitted to be dumped and the location, time and method of dumping;
  - (d) monitor individually, or in collaboration with other Parties and competent international organizations, the condition of the seas for the purposes of this Convention.
2. The appropriate authority or authorities of a Contracting Party shall issue prior special or general permits in accordance with paragraph (1) in respect of matter intended for dumping:
  - (a) loaded in its territory;
  - (b) loaded by a vessel or aircraft registered in its territory or flying its flag, when the loading occurs in the territory of a State not party to this Convention.
3. In issuing permits under sub-paragraphs (1) (a) and (b) above, the appropriate authority or authorities shall comply with Annex III, together with such additional criteria, measures and requirements as they may consider relevant.
4. Each Contracting Party, directly or through a Secretariat established under a regional agreement, shall report to the Organization, and where appropriate to other Parties, the information specified in sub-paragraphs (c) and (d) of accordance with paragraph (3) above.

The procedure to be followed and the nature of such reports shall be agreed by the Parties in consultation.

Article VII - XXII omitted

ANNEX I

1. Organohalogen compounds.
2. Mercury and mercury compounds
3. Cadmium and cadmium compounds.
4. Persistent plastics and other persistent synthetic materials, for example, netting and ropes, which may float or may remain in suspension in the sea in such a manner as to interfere materially with fishing, navigation or other legitimate uses of the sea.
5. Crude oil, fuel oil, heavy diesel oil, and lubricating oils, hydraulic fluids, and any mixtures containing any of these, taken on board for the purpose of dumping.
6. High-level radio-active wastes or other high-level radio-active matter, defined on public health, biological or other grounds, by the competent international body in this field, at present the International Atomic Energy Agency, as unsuitable for dumping at sea.
7. Materials in whatever form (e.g. solids, liquids, semi-liquids, gases or in a living state) produced for biological and chemical warfare.
8. The preceding paragraphs of this Annex do not apply to substances which are rapidly rendered harmless by physical, chemical or biological processes in the sea provided they do not:
  - (i) make edible marine organisms unpalatable, or
  - (ii) endanger human health or that of domestic animals.The consultative procedure provided for under Article XIV should be followed by a Party if there is doubt about the harmlessness of the substance.
9. This Annex does not apply to wastes or other materials (e.g. sewage sludges and dredged spoils) containing the matters referred to in paragraphs 1-5 above as trace contaminants. Such wastes shall be subject to the provisions of Annexes II and III as appropriate.
- 10.<sup>11</sup> Paragraphs 1 and 5 of this Annex do not apply to the disposal of wastes or other matter referred to in these paragraphs by means of incineration at sea. Incineration of such wastes or other matter at sea requires a prior special permit.

ANNEX II

The following substances and materials requiring special care are listed for the purposes of Article VI(1)(a).

- A. Wastes containing significant amounts of the matters listed below:
- |  |   |                     |
|--|---|---------------------|
| arsenic  | } | and their compounds |
| lead   |   |                     |
| copper   |   |                     |
| zinc   |   |                     |
| organosilicon compounds                                  |   |                     |
| cyanides   |   |                     |
| fluorides  |   |                     |
| pesticides and their by-products not covered in Annex I. |   |                     |

---

<sup>11</sup> Paragraph 10 was added to the original text by the Third Consultative Meeting of Contracting Parties in 1978.

B. In the issue of permits for the dumping of large quantities of acids and alkalis, consideration shall be given to the possible presence in such wastes of the substances listed in paragraph A and to the following additional substances:

beryllium	}	and their compounds
chromium		
nickel		
vanadium		

C. Containers, scrap metal and other bulky wastes liable to sink to the sea bottom which may present a serious obstacle to fishing or navigation.

D. Radio-active wastes or other radio-active matter not included in Annex I. In the issue of permits for the dumping of this matter, the Contracting Parties should take full account of the recommendations of the competent international body in this field, at present the International Atomic Energy Agency.

E.<sup>12</sup> In the issue of special permits for the incineration of substances and materials listed in this Annex, the Contracting Parties shall apply the Regulations for the Control of Incineration of Wastes and Other Matter at Sea set forth in the Addendum to Annex I and take full account of the Technical Guidelines on the Control of Incineration of Wastes and Other Matter at Sea adopted by the Contracting Parties in consultation, to the extent specified in these Regulations and Guidelines.

F.<sup>13</sup> Substances which, though of a non-toxic nature, may become harmful due to the quantities in which they are dumped, or which are liable to seriously reduce amenities.

### ANNEX III

Provision to be considered in establishing criteria governing the issue of permits for the dumping of matter at sea, taking into account Article IV(2), include:

#### A — Characteristics and composition of the matter

1. Total amount and average composition of matter dumped (e.g. per year).
2. Form, e.g. solid, sludge, liquid, or gaseous.
3. Properties: physical (e.g. solubility and density), chemical and biochemical (e.g. oxygen demand, nutrients) and biological (e.g. presence of viruses, bacteria, yeasts, parasites).
4. Toxicity.
5. Persistence: physical, chemical and biological.
6. Accumulation and biotransformation in biological materials or sediments.
7. Susceptibility to physical, chemical and biochemical changes and interaction in the aquatic environment with other dissolved organic and inorganic materials.
8. Probability of production of taints or other changes reducing marketability of resources (fish, shellfish, etc.).

---

<sup>12</sup> Paragraph E adopted as an amendment by the Third Consultative Meeting of Contracting Parties in 1978.

<sup>13</sup> Paragraph F adopted as an amendment by the Fifth Consultative Meeting of Contracting Parties in 1980.

## **B — Characteristics of dumping site and method of deposit**

1. Location (e.g. co-ordinates of the dumping area, depth and distance from the coast), location in relation to other areas (e.g. amenity areas, spawning, nursery and fishing areas and exploitable resources).
2. Rate of disposal per specific period (e.g. quantity per day, per week, per month).
3. Methods of packaging and containment, if any.
4. Initial dilution achieved by proposed method of release.
5. Dispersal characteristics (e.g. effects of currents, tides and wind on horizontal transport and vertical mixing).
6. Water characteristics (e.g. temperature, pH, salinity, stratification, oxygen indices of pollution — dissolved oxygen demand (BOD) — nitrogen present in organic and mineral form including ammonia, suspended matter, other nutrients and productivity).
7. Bottom characteristics (e.g. topography, geochemical and geological characteristics and biological productivity).
8. Existence and effects of other dumpings which have been made in the dumping area (e.g. heavy metal background reading and organic carbon content).
9. In issuing a permit for dumping, Contracting Parties should consider whether an adequate scientific basis exists for assessing the consequences of such dumping, as outlined in this Annex, taking into account seasonal variations.

## **C — General considerations and conditions**

1. Possible effects on amenities (e.g. presence of floating or stranded material, turbidity, objectionable odour, discolouration and foaming).
2. Possible effects on marine life, fish and shellfish culture, fish stocks and fisheries, seaweed harvesting and culture.
3. Possible effects on other uses of the sea (e.g. impairment of water quality for industrial use, underwater corrosion of structures, interference with ship operations from floating materials, interference with fishing or navigation through deposit of waste or solid objects on the sea floor and protection of areas of special importance for scientific or conservation purposes).
4. The practical availability of alternative land-based methods of treatment, disposal or elimination, or of treatment to render the matter less harmful for dumping at sea.

## APPENDIX 5

### (1) CRITERIA FOR THE REMOVAL OF MERCURY CONTAMINATED SEDIMENTS

$$C = 0.18 (\Delta H/J)S^{-1}$$

- where C: criteria for the removal of mercury contaminated sediments (ppm)  
 $\Delta H$ : mean tidal range (m)  
 J: ratio of mercury concentration in sediments and dissolved mercury in the bottom water.  
 (approximately 0.0002 — 0.002)  
 S: Safety multiplier

Source: Kankyo Roppou (Environmental Legislation in Japan), Environmental Agency, The Gov. of Japan, 1990

### (2) ESTIMATION OF THE AMOUNT OF POLLUTANTS

#### Pollutants generated by settlements of people

BOD	SS	T-N	T-P	PO <sub>4</sub> -P
36 - 54	28 - 41	7 - 14	1.4 - 2.9	1.1

(Unit: gram/person/day)

Source: Guidelines for sewage treatment system, Japan Sewerage Association, 1983

FIGURE A.1 Relationship between the rate of attainment of BOD and population density

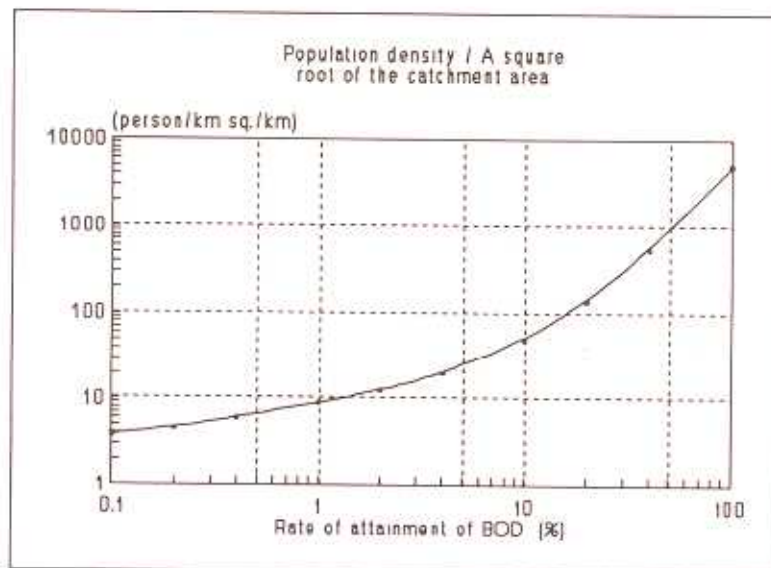

Source: Guidelines for sewage treatment system, Japan Sewerage Association, 1983

*Example:*

If there is a population of 300,000 in a catchment area of 200 km<sup>2</sup>, the value of Y, population density per a stretch of the catchment area, is about 106 (= 300,000/200/200<sup>1/2</sup>). The rate of attainment, is 15 percent as indicated by figure 3.2.

## APPENDIX 6

### (1) NITTA'S EXPERIMENTAL EQUATION

$$\log A = 1.226 \log Q + 0.0855$$

where Q: discharge (m<sup>3</sup>/day)  
A: diffusion area (m<sup>2</sup>)

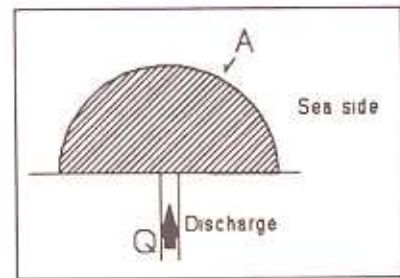

FIGURE A.2 Model of Nitta's equation

Example:

When a discharge (Q) is 2.39 m<sup>3</sup>/s, (i.e., 206,496 m<sup>3</sup>/day), the diffusion area (A) is calculated as 3,995,597 m<sup>2</sup> from the above equation. The distance (r) from a discharge point to the boundary, where no significant difference in concentration level can be seen, is also obtained on the assumption that diffusion occurs in the same speed to every possible direction. In case of figure 3.3, the semicircle is a diffusion area and the distance (r) of diffusion is:

$$A = \pi r^2 / 2$$

$$\pi r^2 / 2 = 3,995,597$$

$$r = 1,595 \text{ (m)}$$

### (2) JOSEPH-SENDNER'S EQUATION

$$S = (S_0 - S_1) [1 - \exp\{-Q(1/r - 1/r_1) / \pi d p\}]$$

where S: concentration at the distance (r) from the point of discharge (mg/l = ppm)  
S<sub>0</sub>: concentration level of discharged water at the outfall (mg/l)  
S<sub>1</sub>: concentration in the background (mg/l)  
Q: discharge per unit time (m<sup>3</sup>/day)  
d: mixing depth (m)  
p: speed of diffusion (m/day); usually 1 ± 0.5 cm/s (864 ± 432 m/day)  
r<sub>1</sub>: distance from the point of discharge to the boundary of diffusion where no significant difference in concentration may be seen. This distance "r<sub>1</sub>" can be obtained from Nitta's equation.

FIGURE A.3 Model of Joseph-Sendner's equation

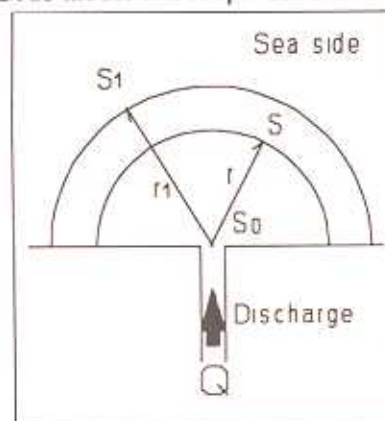

**Example:** BOD is selected as an indicator of water pollution. In the case under consideration, the present concentration levels of BOD in discharged water ( $S_0$ ) and background water ( $S_1$ ) are 2.0 mg/l and 1.5 mg/l respectively. The volume of discharge ( $Q$ ) is 206,496 m<sup>3</sup>/day, mixing depth ( $d$ ) is 2 metres, speed of diffusion ( $p$ ) is 864 m/day, and distance to boundary ( $r_i$ ) is 1,595 metres as in subsection 4.1.2.1. In the future,  $S_0$  increases to 2.6 mg/l, and  $Q$  increases to 216,259 m<sup>3</sup>/day, and other parameters remain at present levels. Concentration level ( $S$ ) at the distance of  $r$  from the discharge point is calculated as shown in the following table.

Concentration levels of BOD at a distance of  $r$

Distance ( $r$ ) (m)	0	50	100	133	200	500	1,000	1,595	1,642
Present (mg/l)	2.0	1.76	1.65	1.62	1.58	1.52	1.50	1.50	1.50
Future (mg/l)	2.6	2.09	1.84	1.77	1.68	1.56	1.52	1.50	1.50

### (3) BOX MIXING MODEL

FIGURE A.4 Box mixing model

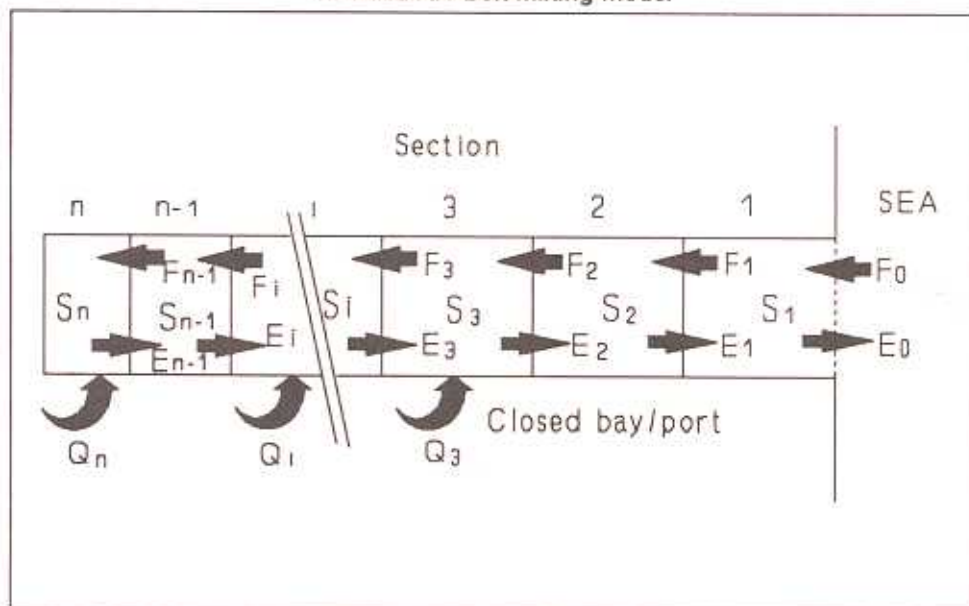

Balance of inflow and outflow of pollutants

$$\text{Section 1: } (F_1 + E_2)S_1 = F_0S_0 + E_1S_2 + Q_1$$

$$\text{Section 2: } (F_2 + E_1)S_2 = F_1S_1 + E_2S_3 + Q_2$$

$$\text{Section } i: (F_i + E_{i+1})S_i = F_{i-1}S_{i-1} + E_iS_{i+1} + Q_i$$

$$\text{Section } n: E_{n-1}S_n = F_{n-1}S_{n-1} + Q_n$$

- where
- $S_0$ : concentration level in outer sea water (mg/l)
  - $S_i$ : concentration level at section  $i$  (mg/l)
  - $Q_i$ : pollutants discharged into section  $i$  during a tidal period (about 12 hours)
  - $F_i$ : volume passing through the boundary between section  $i$  and  $i+1$  during inflow
  - $E_i$ : volume passing through the boundary between section  $i$  and  $i+1$  during outflow

A simple way to estimate  $F_i$  is to calculate a volume of tidal amplitude in sections from  $i$  to  $n$ .  $E_i$  equals the sum of  $F_i$  and the amount of discharges into sections from  $i$  to  $n$ .

**Example:** The case under consideration is a port developed in a bay as shown in figure 3.6 where suspended solids (SS) are discharged from dredging and overflow from a landfill. The water area is divided in three parts (sections 1 to 3). Predict concentration levels of SS in each section using the box mixing model.

Inputs for the model:

Discharge of SS into the Section 2:

- 0.2 tons per tidal cycle due to overflow from a pond in the landfill
- 4.0 tons per tidal cycle from the dredging operation

Area of each section:

- Section 1: 2,000,000 m<sup>2</sup>
- Section 2: 1,080,000 m<sup>2</sup>
- Section 3: 480,000 m<sup>2</sup>

Volume of discharge:

- from Section 1 to 2: 67,050 m<sup>3</sup> per tidal cycle
- from Section 1 to 3: 88,030 m<sup>3</sup> per tidal cycle

Tidal range: 3 m

FIGURE A.5 Example of application of box mixing model

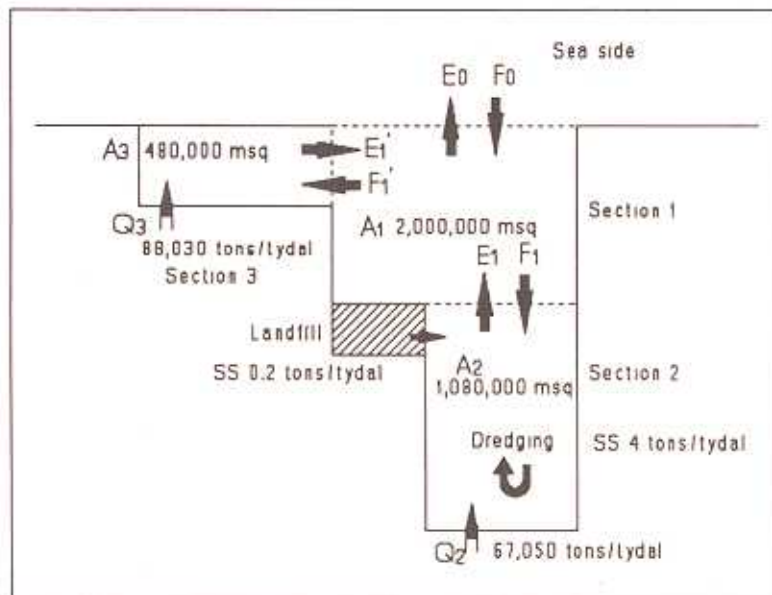

### Output of the model

Inflow and outflow are calculated as follows:

Section	Area (m <sup>2</sup> )	Water volume difference between high and low tide (m <sup>3</sup> )	Water discharged (m <sup>3</sup> )	Inflow (m <sup>3</sup> )	Outflow (m <sup>3</sup> )	Generated pollutants (ton)
1	2,000,000	6,000,000	0	(E <sub>0</sub> ) 10,835,080	(F <sub>0</sub> ) 10,680,000	0
2	1,080,000	3,240,000	67,050	(E <sub>1</sub> ) 3,307,050	(F <sub>1</sub> ) 3,240,000	4.2
3	480,000	1,440,000	88,030	(E <sub>1</sub> ) 1,528,030	(F <sub>1</sub> ) 1,440,000	0

where A: difference of water volume between high and low tide (m<sup>3</sup>)  
 B: inflow water volume per tidal cycle (m<sup>3</sup>/tidal cycle)  
 E<sub>1</sub>: inflow water volume to section 1 (m<sup>3</sup>/tidal cycle)  
 F<sub>1</sub>: outflow water volume from section 1 (m<sup>3</sup>/tidal cycle)  
 q: amount of discharged SS (tons/tidal cycle)

Balance of pollutants:

Section 1:  $(E_0 + F_1 + F_1')S_1 = F_0S_0 + E_1S_2 + E_1'S_3$   
 Section 2:  $E_1S_2 = F_1S_1 + q_2$   
 Section 3:  $E_1'S_3 = F_1'S_1$

where S<sub>i</sub> is the concentration level in section i

Concentration level of each section:

Outside: SS level in outer sea water S<sub>0</sub> is assumed to be zero  
 Section 1:  $15,515,080 S_1 = 3,307,050 S_2 + 1,528,030 S_3$   
 Section 2:  $3,307,050 S_2 = 3,240,000 S_1 + 4.2$   
 Section 3:  $1,528,030 S_3 = 1,440,000 S_1$

S<sub>1</sub> = 0.39 g/m<sup>3</sup> (0.39 ppm)  
 S<sub>2</sub> = 1.65 g/m<sup>3</sup> (1.65 ppm)  
 S<sub>3</sub> = 0.37 g/m<sup>3</sup> (0.37 ppm)

## APPENDIX 7 DISPERSAL OF THERMAL DISCHARGE

FIGURE A.6 Temperature boost by thermal discharge<sup>14</sup>

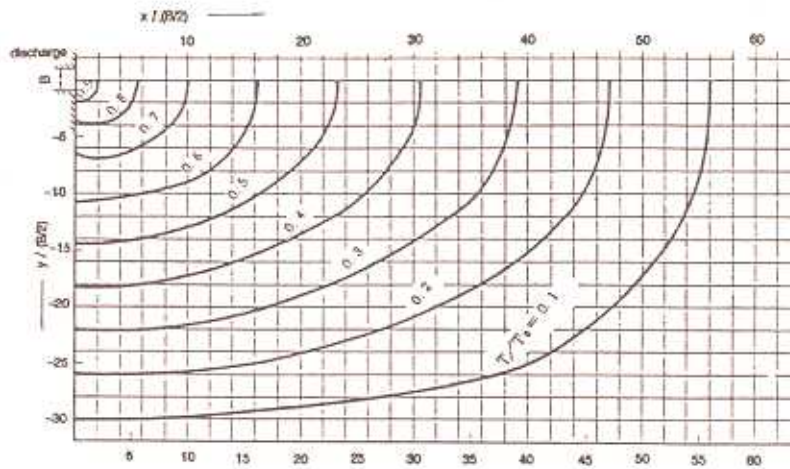

where  $T$ : temperature boost in the surface water ( $^{\circ}\text{C}$ )  
 $T_0$ : temperature boost in thermal discharge ( $^{\circ}\text{C}$ )  
 $B$ : width of the outfall (m)  
 Discharge speed: 1 m/s  
 Depth of thermocline: 3 m

*Example:* In the case under consideration, a power plant intakes cooling water from the sea and discharges the water boosted by 5 degrees. The width of outfall is 4 m ( $B$ ) and the speed of discharge is 1 m/m. Where is the contour line of  $1^{\circ}\text{C}$  up in the surface water?

Using figure 3.7, find the contour of  $T/T_0 = 0.2$  ( $1^{\circ}/5^{\circ}$ ) and read  $x$  and  $y$  axes where the contour crosses,  $x = 47$ ,  $y = 26$ . As  $x/(B/2) = 47$ ,  $y/(B/2) = 26$ , and  $B = 4$ , the distance of  $1^{\circ}$  up contour is 94 m offshore and 52 m longshore.

<sup>14</sup>

Study on the diffusion of thermal discharge, A. Wada, Electric Power Research Institute, Japan, 1966

## APPENDIX 8 DISPERSAL OF TURBID WATER

Approximate quantity of SS generated by dredging or dumping operations

Activity \ Type of the bottom	SS generated by dredging or dumping of one cubic metre of sandy material	SS generated by dredging or dumping of one cubic meter of silt/clay
Pump dredging Ordinary 4,000 PS <sup>1/</sup> Ordinary 2,000 PS  Low-pollution type 1,600 PS Low-pollution type 800 PS	kg/m <sup>3</sup> (2) 2.2-4.5 (3) 0.1-0.3  NA NA	kg/m <sup>3</sup> (2) 1.2-1.4 NA (3) 1.2-1.6 (2) 1.5-3.5
Grab dredging Ordinary 8 m <sup>3</sup> bucket Ordinary 3 m <sup>3</sup> bucket  Water-tight type 8 m <sup>3</sup> bucket	NA (1) 8.4  NA	(2) 10-89 (4) 12-84  (1) 3.5
Bucket dredger	(1) 17	(1) 56
Dumping by grab bucket from hopper barge	(11) 0.4-5.0 (2) 2.4-5.2	NA (5) 12- 203

Note: Parentheses are the number of times of observations

NA: Not Available

<sup>1/</sup> Capacity of pump in Horse Power

Source: Assessment Manual for Dredging and Reclamation, Ministry of Transport, Japan, 1982

FIGURE A.7 Turbid water patterns from dredging and dumping<sup>15</sup>

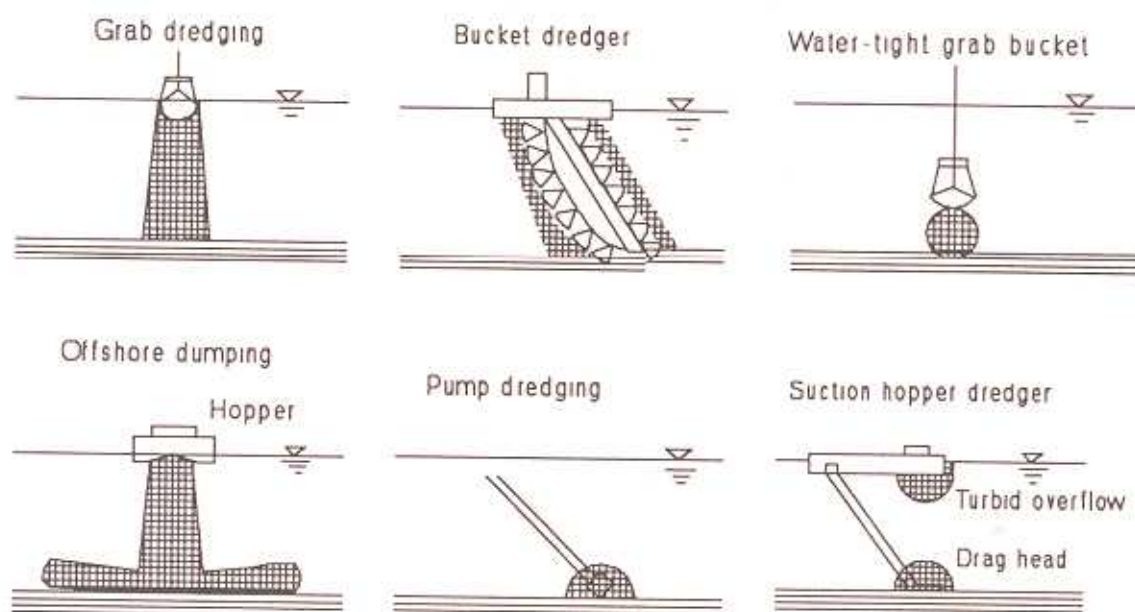

<sup>15</sup> Assessment Manual for Dredging and Reclamation, Ministry of Transport, Japan, 1983

FIGURE A.8 Relationship between particle size and marginal current velocity<sup>16</sup>

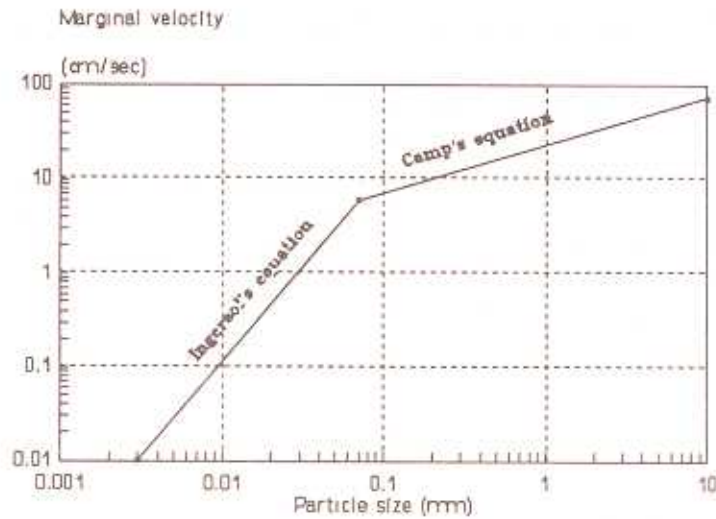
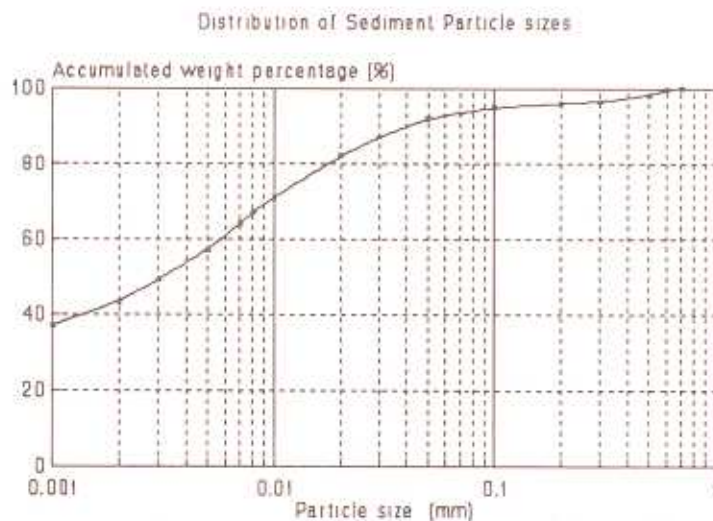

FIGURE A.9 A typical distribution of sediment particle sizes of silt<sup>17</sup>



*Example:* If the current speed is 1 cm/s at the dredging site, the maximum particle size that can be suspended in water is 0.03 mm as shown by figure 3.9. The accumulated weight percentage up to 0.03 mm is 87 per cent in the case of figure 3.10. This indicates that 87 per cent of SS generated by dredging or dumping will disperse in the sea and increase the concentration of SS.

<sup>16</sup> See footnote 4

<sup>17</sup> See, for instance, reference 18

APPENDIX 9 TYPICAL PATTERNS OF BEACH EROSION AND ACCRETION

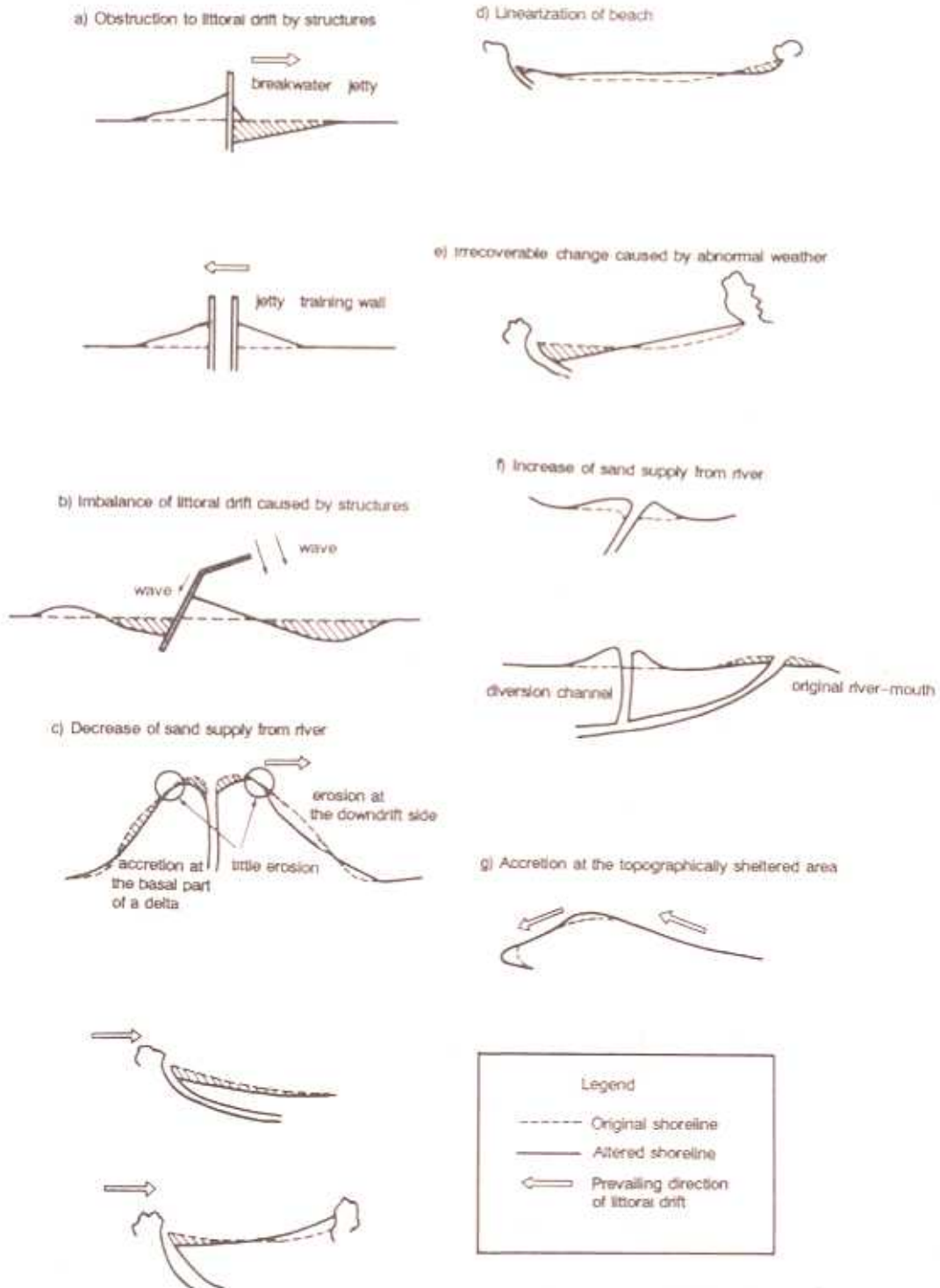

FIGURE A.9 Typical patterns of beach erosion and accretion

## APPENDIX 10 LEVELS OF EUTROPHICATION

Pollution level Environmental indicator	Saprotrophic water (extremely polluted)	Petrophic water (severely polluted)		Eutrophic water (slightly polluted)	Oligotrophic water (clean)
		Deep water area (more than several metres)	Shallow water area (less than several metres)		
<b>WATER QUALITY</b>					
Transparency (m)	≤ 3	≤ 3		3 - 10	≥ 10
Discolouration	Blackish	Yellow, olive, brownish, etc.		Temporal and local colouring	No colouring
COD (ppm)	≥ 10	3 - 10		1 - 3	≤ 1
BOD (ppm)	≥ 10	3 - 10		1 - 3	≤ 1
DO saturation (%)	0 - 30 % (anaerobic condi- tion from surface layer to the sea bottom)	100 - 200 % at surface layer (oversaturated), 0 - 30 % at the bottom layer	100 - 200 % at surface layer (oversaturated)	> 80 % at surface and middle layer, 30 - 80 % deeper layer than several metres	80 - 100 % in all layers (saturated)
Hydrogen sulphide	Detected at most layers	Detectable at the bottom layer	Not detectable	Not detectable	Not detectable
Inorganic N compounds (μg at N/l)	≥ 100	10 - 100		2 - 10	≤ 2
<b>BOTTOM SEDIMENTS</b>					
Colour of sediments	Black. Oxidation layer (brownish layer at the sur- face of the bot- tom) not found	Black. Oxidation layer not found	Blackish. Oxidation layer found	Occasionally blackish. Oxidation layer found	Natural. Oxidation layer found
COD (mg/g)	-	> 30		5 - 30	< 5
Sulphide (mg/g)	> 1.0	0.3 - 3.0		0.03 - 0.3	< 0.03
<b>AQUATIC BIOTA</b>					
Bacteria (cell no./ml)	≥ 10 <sup>5</sup>	10 <sup>3</sup> - 10 <sup>5</sup>		10 <sup>2</sup> - 10 <sup>4</sup>	≤ 10 <sup>2</sup>
Phytoplankton (cell no./ml)	≤ 10 <sup>3</sup>	10 <sup>3</sup> - 10 <sup>5</sup>		10 <sup>1</sup> - 10 <sup>3</sup>	≤ 10 <sup>1</sup>
Chlorophyll (mg/m <sup>3</sup> )	-	10 - 200		1 - 10	< 1
Primary production (mgc/m <sup>2</sup> /hr)	-	10 - 200		1 - 10	< 1
(Gc/m <sup>2</sup> /day)	-	1 - 10		0.3 - 1.0	< 0.3
Protozoa	Extremely abundant	Abundant		Scarce	Scarce
Crustacean zooplankton	-	Scarce, little diversity		Abundant, great diversity	Scarce, great diversity
Benthic polychaetes worm	Scarce, little diversity	Scarce, little diversity	Abundant, great diversity	Abundant, great diversity	Scarce, great diversity
Crustacean	-	Scarce, little diversity		Abundant, great diversity	Scarce, great diversity
Typical water area	Enclosed bays or ports with abundant discharge of pollutants			Bays and coastal zone	Offshore open water areas

## APPENDIX 11 GAS EMISSION AND DISPERSION

FIGURE A.10 Maximum concentration levels of airborne pollutants on the ground<sup>18</sup>

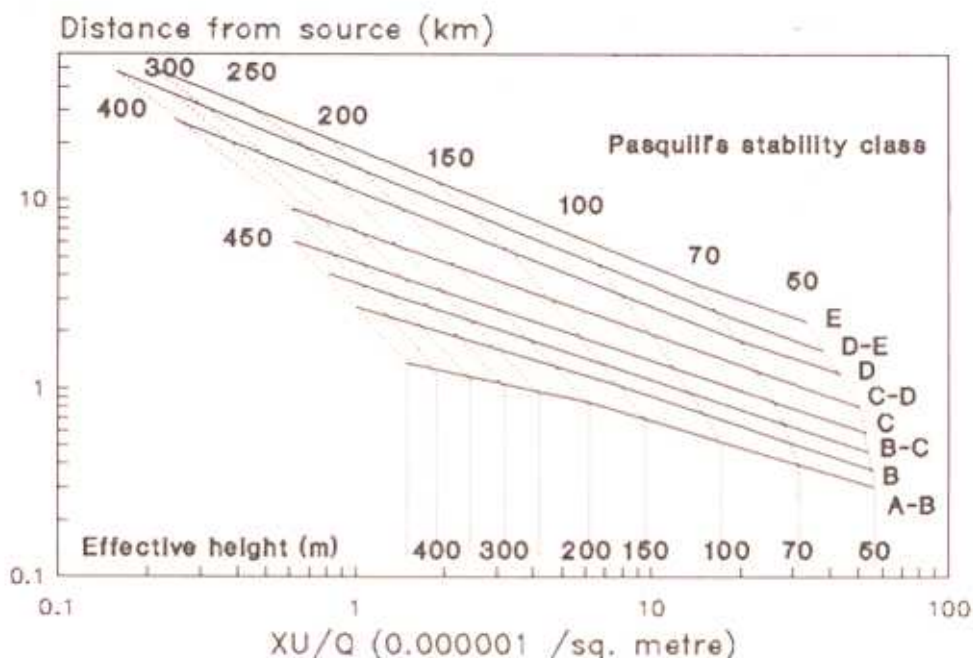

**Example:** If the effective height of a chimney is 70 m, wind speed is 2 m/s, the volume of airborne pollutants is  $0.1 \text{ m}^3/\text{s}$ , and Pasquill's stability class is D, predict where the maximum concentration takes place on the ground and the level of pollutant concentration.

In figure 3.13, a cross point of effective height 70 and Pasquill stability class D is 1.7 on the Y-axis and 200,000 ( $2 \cdot 10^5$ ) on the X-axis. The X-axis shows the value of  $XU/Q$ ,

where:  $X$  = maximum ground level concentration ( $\text{m}^3/\text{m}^3$ )  
 $U$  = wind speed at the point of discharge (m/s)  
 $Q$  = volume of discharge per unit time ( $\text{m}^3/\text{s}$ )

From  $XU/Q = 2 \cdot 10^5$ ,  $X = 2 \cdot 10^5 \cdot Q/U = 2 \cdot 10^5 \cdot 0.1/2 = 10^6$

Therefore, the maximum concentration is 1 ppm at a distance of 1.7 km from the source.

### Pasquill's stability class of atmosphere

Pasquill's stability class	Standard deviation of wind direction changes	Remarks
A	25.0°	Extremely unstable
B	20.0°	Moderately unstable
C	15.0°	Slightly unstable
D	10.0°	Neutral
E	5.0°	Slightly stable
F	2.5°	Moderately stable

Source: Safety guide for water cooled nuclear power plants, Safety Guide 23, Onsite Meteorological Programme (USAEC), 1972

<sup>18</sup> Air Pollution Manual, Environment Agency, Japan

APPENDIX 12

(1) NOISE TRANSMISSION

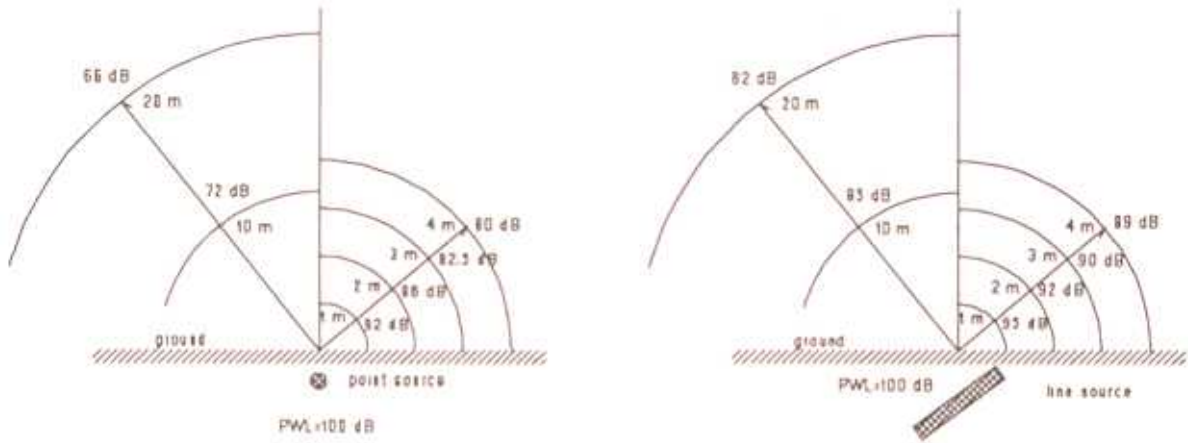

FIGURE A.11 Noise reduction by distance from source

(2) ANGLES OF VIEW

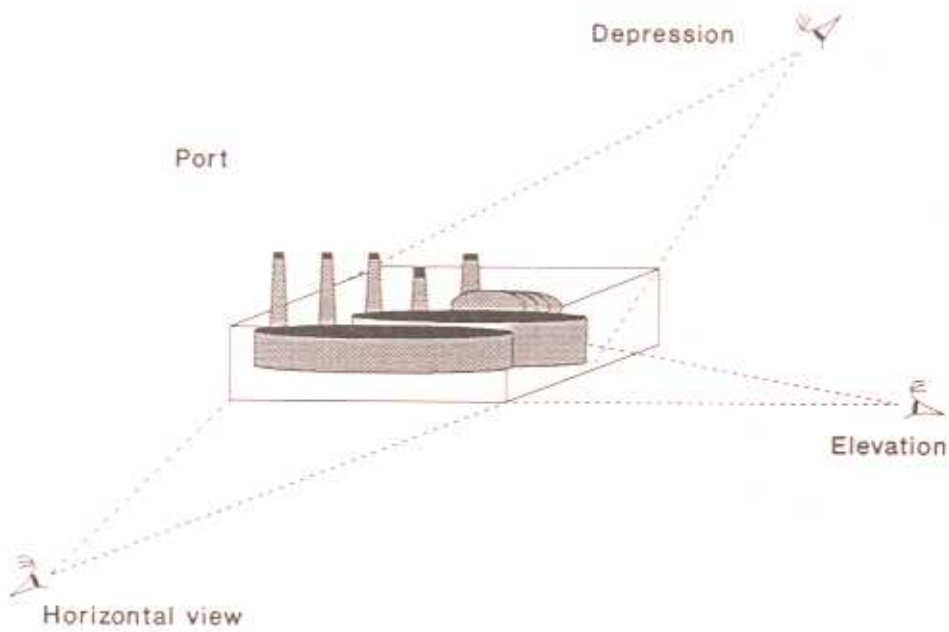

FIGURE A.12 Illustration of angles of view

## APPENDIX 13 TYPES OF SETTLING POND

- (a) Settlement in the landfill (no particular settling pond)

Applicable to a large landfill site without any particular settling pond.



- (b) Settlement by coagulants (no particular settling pond)

Encourage the settlement of fine particles using coagulants.

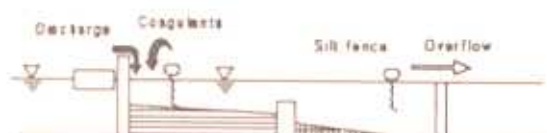

- (c) Separated settling pond in the landfill area

Reclamation area is divided into several blocks and one or two are used as settling pond.



- (d) Settlement by coagulants in a separated settling pond

Use one or two blocks as settling ponds and encourage the settlement by coagulants.

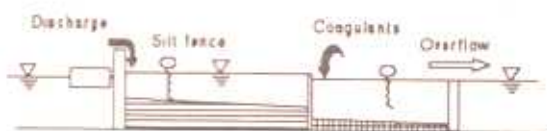

- (e) Filtration by sand filter after a settling pond

Discharge water through sand filter.

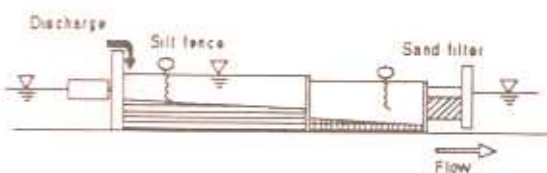

- (f) Mixing of coagulants and filtration of the discharge

Special attention for the quality of discharge water from reclamation site.

